

## Self-Contained Freewheels

# AL..F2D2 AL..F4D2



Back of  
AL..F2D2

Back of  
AL..F4D2

## TYPE



AL..F2D2

AL..F4D2

Types AL..F2D2/F4D2 are roller type freewheels, self-contained, sealed and bearing supported, using two 160.. series bearings. Units are delivered oil lubricated.

Primarily used as overrunning or indexing clutches, the cover combination is chosen according to the type of drive, as shown overleaf. D2 cover is used to close the unit.

It is equipped with two screws for oil filling, drain and level. The shaft seal is a V-ring type. Cover and seal have been designed to be oil proof with minimum drag torque.

We recommend the unit is supplied assembled. Please specify inner race direction of rotation seen from the D2 flange.

# Self-Contained Freewheels

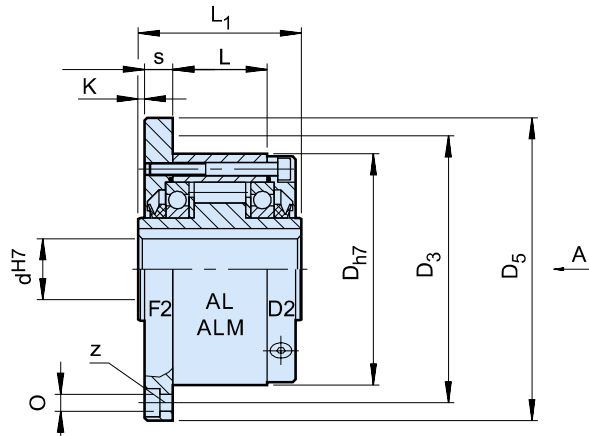

**AL..F2D2**

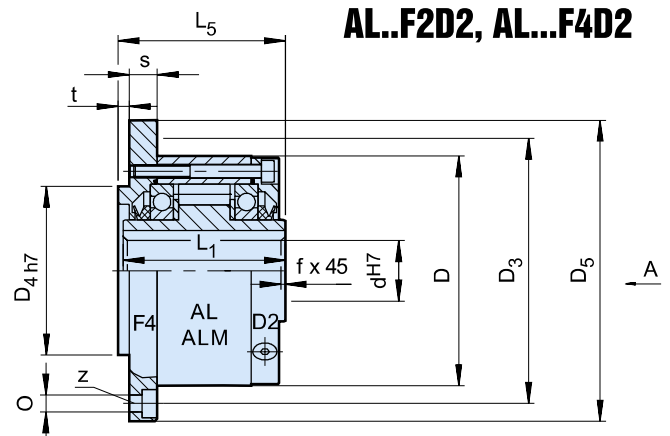

**AL..F4D2**

Type	Size	Overrunning speeds				Number										Weight	Drag torque	
		$T_{KN}^{1)}$ [Nm]	$n_{imax}^{2)}$ [min <sup>-1</sup> ]	$n_{omax}^{3)}$ [min <sup>-1</sup> ]	$D_{h7}$ [mm]	$L_1$ [mm]	$D_5$ [mm]	$D_3$ [mm]	$z$	$O$ [mm]	$D_{4h7}$ [mm]	$t$ [mm]	$L_5$ [mm]	$K$ [mm]	$s$ [mm]			$f$ [mm]
AL..F2D2 AL..F4D2	12	55	2500	7200	62	42	85	72	3	5,5	42	3	44	0,5	10,3	0,5	0,9	11
	15	125	1900	6500	68	52	92	78	3	5,5	47	3	54	0,5	10,3	0,8	1,3	15
	20	181	1600	5600	75	57	98	85	4	5,5	55	3	59	0,5	10,8	0,8	1,7	18
	25	288	1400	4500	90	60	118	104	4	6,6	68	3	62	0,5	10,5	1	2,6	36
	30	500	1300	4100	100	68	128	114	6	6,6	75	3	70	0,5	11,3	1	3,5	48
	35	725	1100	3800	110	74	138	124	6	6,6	80	3,5	76	1	11,8	1	4,5	60
	40	1025	950	3400	125	86	160	142	6	9	90	3,5	88	1	13,8	1,5	6,9	84
	45	1125	900	3200	130	86	165	146	8	9	95	3,5	88	1	13,8	1,5	7,1	94
	50	2125	850	2800	150	92	185	166	8	9	110	4	94	1	12,8	1,5	10,1	128
	55	2625	720	2650	160	104	204	182	8	11	115	4	106	1,5	16,8	2	13,1	150
	60	3500	680	2450	170	114	214	192	10	11	125	4	116	1,5	16,3	2	15,6	160
	70	5750	580	2150	190	134	234	212	10	11	140	4	136	1,5	17,8	2,5	20,4	360
	80	8500	480	1900	210	144	254	232	10	11	160	4	146,3	1,5	20,3	2,5	26,7	360
	90	14500	380	1700	230	158	278	254	10	14	180	4,5	161	1,5	20	3	39	680
	100	20000	350	1450	270	182	335	305	10	18	210	5	184	2,5	28	3	66	880
	120	31250	250	1250	310	202	375	345	12	18	240	5	204	2,5	28,5	3	91	1200
150	70000	180	980	400	246	485	445	12	22	310	5	249	2,5	31	4	186	1350	
200	175000	120	750	520	326	625	565	18	26	400	5	328	3	40	5	425	4200	
250	287500	100	620	610	396	740	680	20	33	480	5	398	3	45	5	680	6500	
ALM..F2D2 ALM..F4D2	25	388	1100	2800	90	60	118	104	4	6,6	68	3	62	0,5	10,5	1	2,7	41
	30	588	1000	2500	100	68	128	114	6	6,6	75	3	70	0,5	11,3	1	3,65	64
	35	838	900	2400	110	74	138	124	6	6,6	80	3,5	76	1	11,8	1	4,7	76

**NOTES**

1)  $T_{max} = 2 \times T_{KN}$   
 » Refer to Selection page 7 to 11

2) Inner race overruns

3) Outer race overruns  
 Keyway to DIN 6885.1

When ordering, please specify direction of rotation seen from arrow

A": „R“ Inner race overruns in clockwise direction, „L“ Inner race overruns in counterclockwise

» Refer to mounting and maintenance instructions page 12 to 13

**MOUNTING EXAMPLE**

