

Centrifugally Lift Off Sprags Freewheels

RSCI 20-130



TYPE



Type RSCI is a centrifugal lift off sprag type freewheel with the inner race rotating. Only the inner race is designed for freewheeling. It is a non self-supported type.

Bearings must be provided to ensure concentricity of the inner and outer races and support axial and radial loads, as shown overleaf. Concentricity and run-out limits must be observed. The RSCI type accepts all types of lubricant currently used in power transmission equipment.

It is possible to mount these freewheels directly in gear-boxes without separate lubrication. An oil mist is generally sufficient. Grease lubrication may be acceptable if the unit works mostly in overrunning condition, as on E-motors.

When used as a backstop, it must be checked that the overrunning speed will not go below the minimum speed given in the characteristics table. Please refer to page 74 (RSCI 180–300) for further information.

Centrifugally Lift Off Sprags Freewheels

RSCI 20-130

RSCI

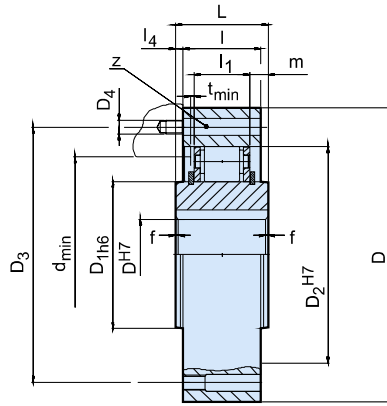

F8

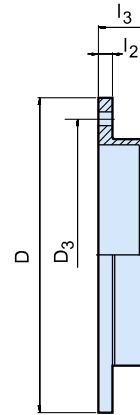

Type	Size	Speeds					Number										Weight						
		$T_{KH}^{1)}$ [Nm]	$n_{max}^{2)}$ [min ⁻¹]	$n_{min}^{3)}$ [min ⁻¹]	$n_{max}^{4)}$ [min ⁻¹]	$D^{5)}$ [mm]	D_{1H6} [mm]	D_{2H7} [mm]	D_3 [mm]	D_4 [mm]	z	L [mm]	l [mm]	l_1 [mm]	l_4 [mm]	$f \times 45^\circ$ [mm]	d_{min} [mm]	m [mm]	t_{min} [mm]	l_2 [mm]	l_3 [mm]	RSCI [kg]	F8 [kg]
RSCI	20	212	315	750	15000	90	36	66	78	M6	6	35	35	25	0	0,8	52	5	1	8	16	1,5	0,3
	25	319	300	725	14000	95	40	70	82	M6	6	35	35	25	0	1,0	56	5	1	8	16	1,6	0,4
	30	375	290	700	11000	100	45	75	87	M6	6	35	35	25	0	1,5	62	5	1	8	16	1,8	0,4
	35	550	280	670	11000	110	50	80	96	M6	8	35	35	25	0	1,5	66	5	1	8	16	2,1	0,5
	40	800	260	630	8000	125	60	90	108	M8	8	35	35	25	0	1,5	76	5	1	10	21	2,7	0,7
	45	912	255	610	7000	130	65	95	112	M8	8	35	35	25	0	1,5	82	5	1	10	21	2,9	0,9
	50	1400	235	560	6000	150	80	110	132	M8	8	40	40	25	0	1,5	100	7,5	1	10	21	4,3	1
	60	2350	210	510	6000	175	85	125	155	M10	8	60	50	36	5	2,0	110	12	2	12	35	6,5	1,8
	70	3050	195	470	4000	190	100	140	165	M10	12	60	50	36	5	2,0	120	12	2	12	35	8,6	1,9
	80	4500	180	440	4000	210	120	160	185	M10	12	70	60	36	5	2,0	140	17	3	12	35	12,5	2,6
	80M	5800	155	375	4000	210	120	160	185	M10	12	70	60	46	5	2,0	140	12	2	12	35	13,1	2,6
	90	5600	170	410	3000	230	140	180	206	M12	12	80	70	36	5	2,5	165	22	3	12	35	17,4	3,0
	90M	8700	145	350	3000	245	140	180	206	M12	12	80	70	46	5	2,5	160	17	2	12	35	18,3	3,0
	100	10500	145	355	3000	290	140	210	258	M16	12	90	80	52,6	5	2,5	180	18,6	3	15	37	28	5,0
	100M	16000	140	340	2400	290	170	210	258	M16	12	90	80	63	5	2,5	200	13,5	2	12	35	30	5,0
130	15750	135	330	2400	322	170	240	278	M16	12	90	80	52,6	5	3,0	210	18,6	3	15	37	35	6,0	

NOTES

- $T_{max} = 2 \times T_{KN}$
» Refer to Selection page 7 to 11
- This maximum allowable torque transmission speed n_{max} must not be exceeded when transmitting torque
- This minimum allowable overrunning speed n_{min} should not be reduced under continuous operation.
Possible reduction of this minimum speed on request
- Inner race overruns
Keyway to DIN 6885.1
- Tolerance +1

Cover F8 must be ordered separately
» Refer to mounting and maintenance instructions
page 12 to 13

Other bore diameters on request

MOUNTING EXAMPLE

