



JIECANG

**TECHNOLOGY
DRIVES
INTELLIGENT LIFE**



ABOUT JIECANG

Zhejiang Jiecang Linear Motion Technology Co. Ltd, was founded in 2000 and was listed in September, 2018 on the Shanghai stock exchange (603583.SH). JIECANG is a technology group focusing on the research, development, production and sales of linear motion products.

The company integrates global resources, provides intelligent motion and control solutions for industries like intelligent office, medical care, intelligent home and industrial automation. Using technology to drive intelligent life.

As a national high-tech enterprise, JIECANG took the lead in drafting of Chinese national industry standard for DC linear actuators and electric lifting tables.

Currently, JIECANG has subsidiaries and production bases in Asia Pacific, Europe and America with a total area of 595,000 square meters and more than 3500 employees.

JIECANG LINEAR MOTION--A RELIABLE PARTNER



AHEAD OF THE FIELD

JIECANG has promoted the industrialization and standardization of the domestic electrical lifting desks industry.



CUSTOMIZATION

With experienced engineering groups, JIECANG is able to customize for its customers innovation.



FINEST WORKMANSHIP

JIECANG pays extremely close attention to details to create the high-quality of products. We focus on research and design, the best raw materials, precise production as well as full extensive tests. A warranty for 5 years is provided.



INNOVATIVE RESEARCH

JIECANG has three R&D centers in Xinchang, Hangzhou and Taiwan with over 200 engineers. Over 400 projects were patented with the cooperation with European and American experts and famous institutions.



PRODUCTION CAPACITY

With fully automatic production lines, JIECANG is capable of timely delivery to domestic and foreign customers with million annual production scale.



GLOBAL BRANCHES

JIECANG has subsidiaries and production bases in Europe, America and Asia, aiming at meeting all our customers' requirements on time. Our services and quality have gained recognition in over 100 countries and thousands of customers worldwide.



STRONG SENSE OF SOCIAL DUTIES

JIECANG takes its corporate social responsibility seriously, which include philanthropic efforts, employee, tax and environmental issues, and give back to society, customers, stockholders and staffs.



INTELLIGENT CYBER SYSTEMS

Bluetooth 5.0 module is connected to the control box of each electric adjustable desk, which is combined with an intelligent gateway to realize the network of adjustable desks and unified controls, station booking, the adjustable desk uses data cloud management.



SMART BOOKING

The smart adjustable desk can be booked through a work card or a mobile phone. If the person leaves with his ID card or mobile phone, the booking will be automatically ended by the system, so that the desk will be updated to "available for booking" again.



VOICE CONTROL

JIECANG develops its own intelligent voice control system to control the operation of the electric adjustable desk.



MOBILE APP

Our APP provides the way to control the adjustable desks more intelligent and convenient. By Bluetooth or QR code scanning, you can change the height of desks, set the memory of the height, use the sedentary reminder and so on.



ANTI-COLLISION TECHNOLOGY

When the electric adjustable desk touches an object during operation, the anti-collision system will activate and immediately stop the movement of the table to prevent collision and injury to the user or the table itself.



GREEN ENERGY-SAVING AND ENVIRONMENTAL PROTECTION

0.1W standby consumption: JIECANG applies advanced power management technology to all control boxes to reduce standby power consumption of the lifting system. PVC free: The cables for the adjustable desk of JIECANG are PVC free. We pay attention to environmental protection and your health.

CERTIFICATION

JIECANG have passed ISO9001, ISO14001, ISO27001, OHSAS18001 and other management systems, and our products have passed UL,CE, ROHS, SAA, PSE, KC, BIFMA and other international certifications.



JC35TS-R13S

1 PERSON DESK FRAME

SURFACE COLOR



Black / White / Silver

Color can be customized

TECHNICAL PARAMETER

Height (mm)	595 ~ 1245	Width (mm)	1085 ~ 1800
Speed (mm/s)	40	Noise (dB)	< 50
Load Capacity (N)	1250		

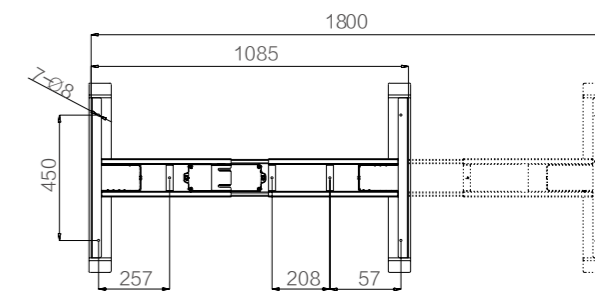
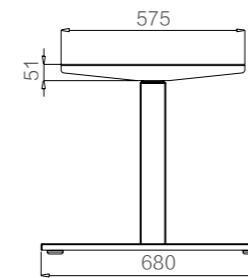
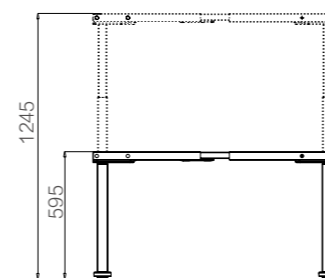

JC35TS – R13SF

ZOOM80 FAST ADJUSTABLE DESK FRAME

SURFACE COLOR

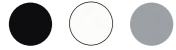

Black / White / Silver

Color can be customized

TECHNICAL PARAMETER

Height (mm)	602 ~ 1252	Width (mm)	1085 ~ 1800
Speed (mm/s)	80	Noise (dB)	< 55
Load Capacity (N)	800		

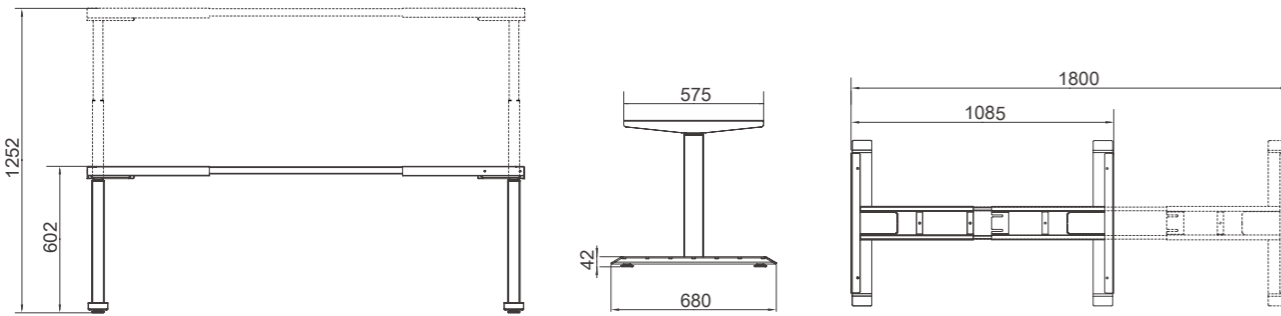

JC35TS – ZS83S

1 PERSON DESK FRAME

SURFACE COLOR



Black / White / Silver

Color can be customized

TECHNICAL PARAMETER

Height (mm)	636 ~ 1286	Width (mm)	1085 ~ 1800
Speed (mm/s)	40	Noise (dB)	< 50
Load Capacity (N)	1250		

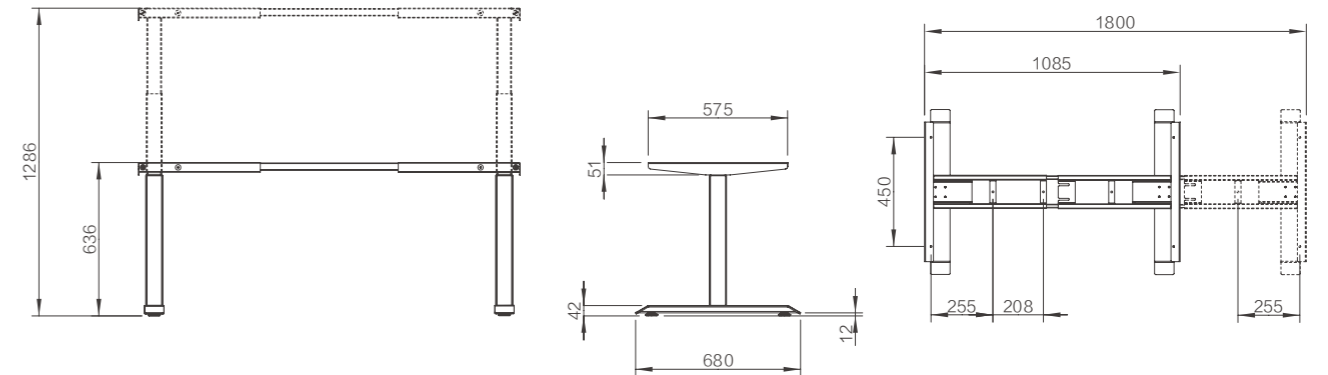

JC35TS-EZ4.0

QUICK INSTALL DESK FRAME

SURFACE COLOR

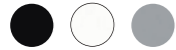

Black / White / Silver

Color can be customized

TECHNICAL PARAMETER

Height (mm)	610 ~ 1260	Width (mm)	1165 ~ 1565
Speed (mm/s)	40	Noise (dB)	< 50
Load Capacity (N)	1250		

INSTALLATION STEPS

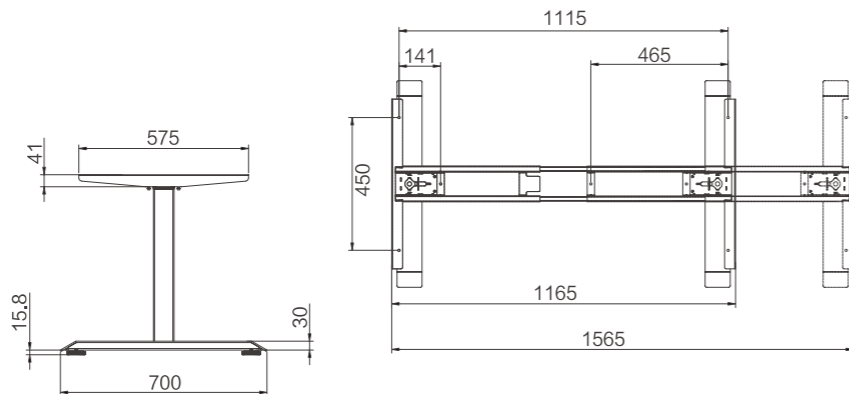
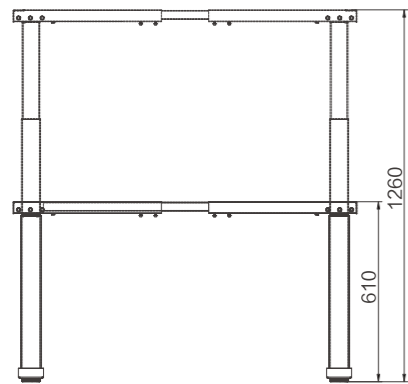

JC35TS-EZ3.0

QUICK INSTALL DESK FRAME

SURFACE COLOR



Black / White / Silver

Color can be customized

TECHNICAL PARAMETER

Height (mm)	605 ~ 1255	Width (mm)	1165 ~ 1585
Speed (mm/s)	40	Noise (dB)	< 50
Load Capacity (N)	1200		

INSTALLATION STEPS

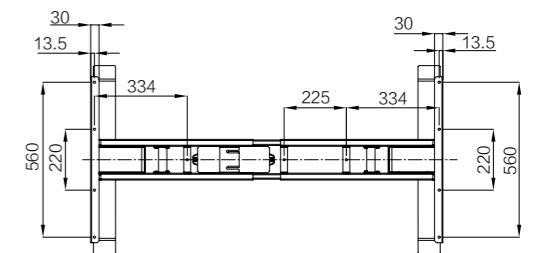
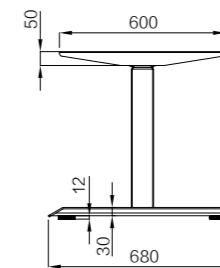
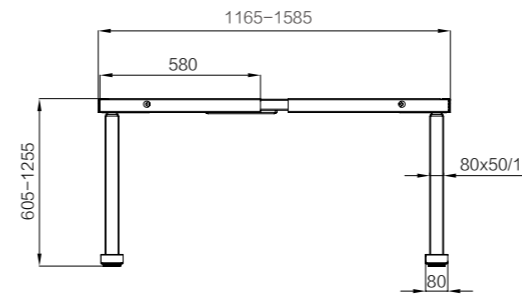
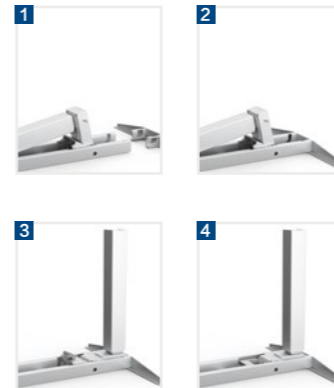

JC35TF-DC2R

ODETTE DESK FRAME

SURFACE COLOR



Black / White / Silver

Color can be customized

TECHNICAL PARAMETER

Height (mm)	700 ~ 1150	Load Capacity (N)	1000
Speed (mm/s)	32	Noise (dB)	< 55

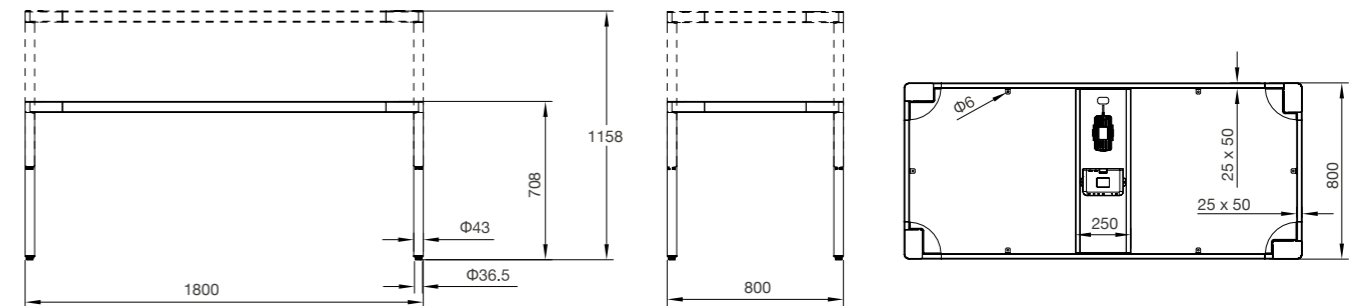



JC35TT-R13S-120°

3 PERSON WORKSTATION DESK FRAME

SURFACE COLOR

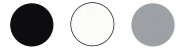

Black / White / Silver

Color can be customized

TECHNICAL PARAMETER

Height (mm)

595 ~ 1245

Speed (mm/s)

40

Load Capacity (N)

1500

Noise (dB)

< 50

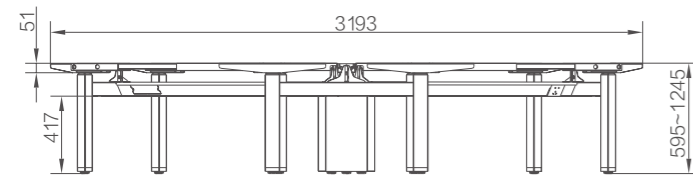
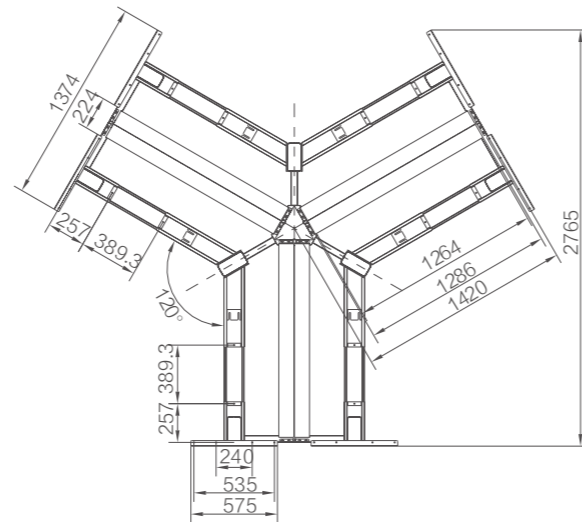

JC35TT-C13S-120°



JC35TT-R13R-90°



JC35TT-R12S-180°



Width (mm)

1050 ~ 1900

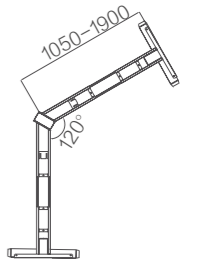
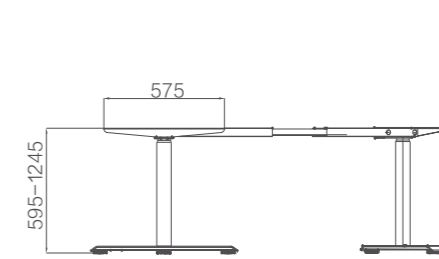

Width (mm)

1085 ~ 1800

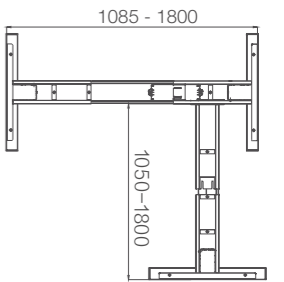
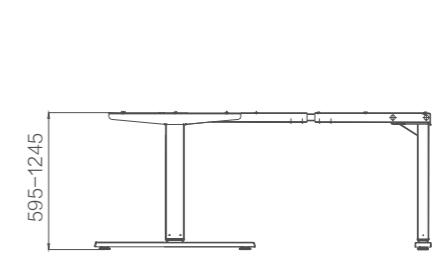

Width (mm)

1995 ~ 2995

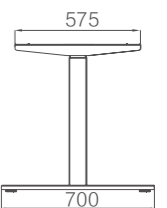
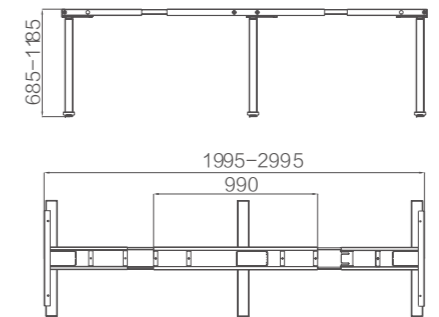



JC35TF-R13S-2

2 PERSON WORKSTATION DESK FRAME

SURFACE COLOR

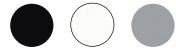

Black / White / Silver

Color can be customized

TECHNICAL PARAMETER

Height (mm)	595 ~ 1245	Width (mm)	1100 ~ 1700
Speed (mm/s)	40	Noise (dB)	< 50
Load Capacity (N)	1250		

FRAME DETAIL

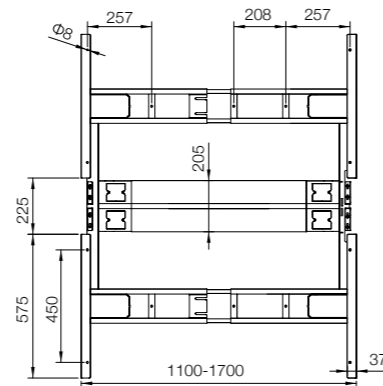
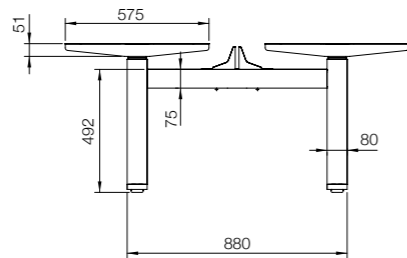
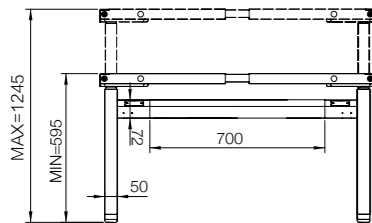
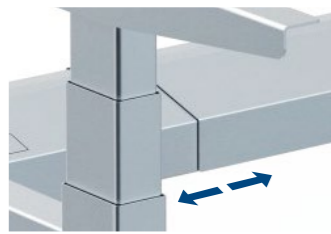

FRAME DETAIL

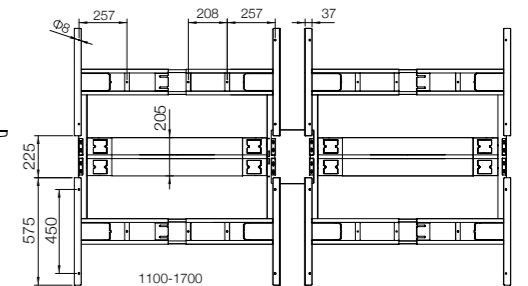
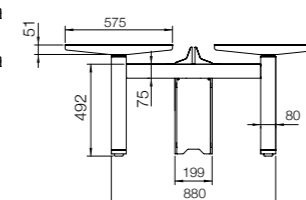
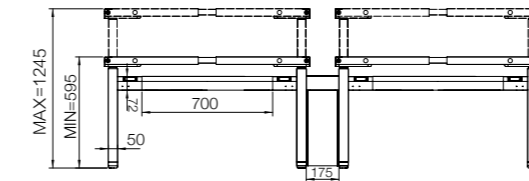
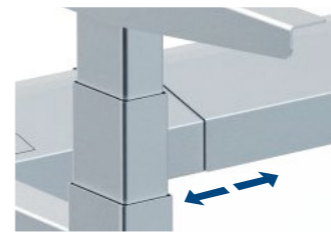

JC35TF-R13S-4

4 PERSON WORKSTATION DESK FRAME

SURFACE COLOR



Black / White / Silver

Color can be customized

TECHNICAL PARAMETER

Height (mm)	595 ~ 1245	Width (mm)	1100 ~ 1700
Speed (mm/s)	40	Noise (dB)	< 50
Load Capacity (N)	1250		

JC35TS-R12R-TH

SINGLE-MOTOR ADJUSTABLE DESK FRAME

SURFACE COLOR

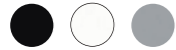

Black / White / Silver

Color can be customized

TECHNICAL PARAMETER

Height (mm)	681 ~ 1180	Load Capacity (N)	700
Speed (mm/s)	25	Noise (dB)	< 50

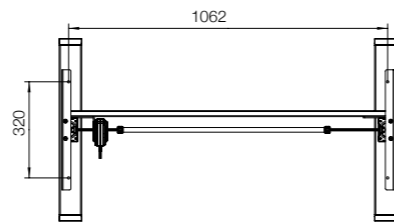
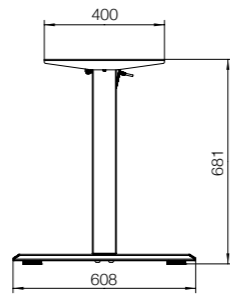
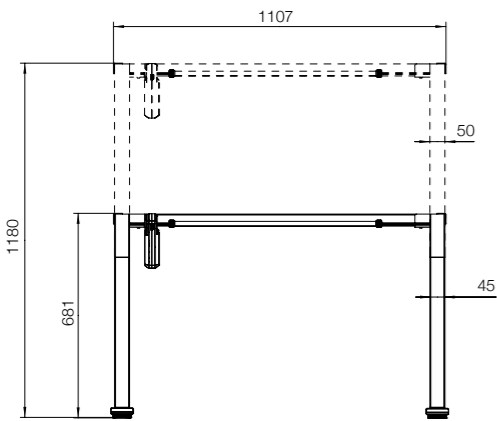

JC35TO-S33S

1 LEG ADJUSTABLE TABLE BASE

SURFACE COLOR



Black / White / Silver

Color can be customized

TECHNICAL PARAMETER

Height (mm)	585 ~ 1235	Load Capacity (N)	800
Speed (mm/s)	40	Noise (dB)	< 50

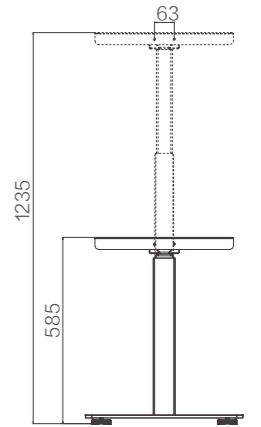
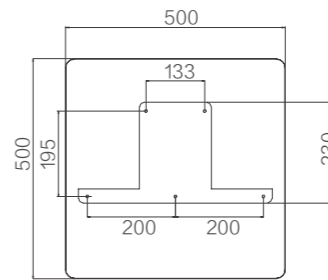
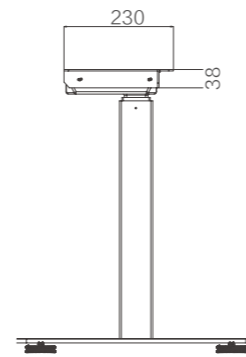

JC35TO-C13S

1 LEG ADJUSTABLE TABLE BASE

SURFACE COLOR

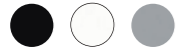

Black / White / Silver

Color can be customized

TECHNICAL PARAMETER

Height (mm)	Load Capacity (N)
595 ~ 1245	500
Speed (mm/s)	Noise (dB)
40	< 50

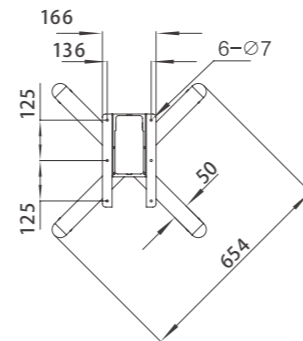
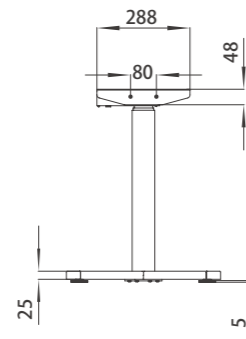
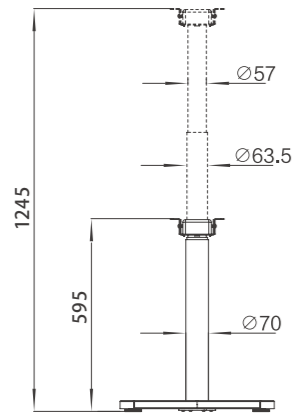

JC35TO-C12R-Q

1 LEG GASDYNAMIC DESK FRAME

SURFACE COLOR



Black / White / Silver

Color can be customized

TECHNICAL PARAMETER

Height (mm)	Reversing Locking (N)
670 ~ 987	1000
Load Capacity (N)	
Can meet customer needs	

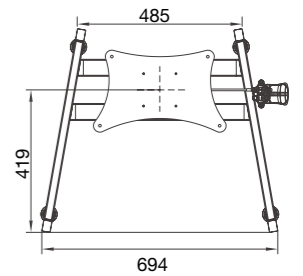
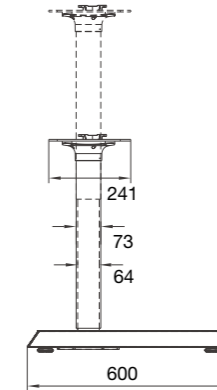
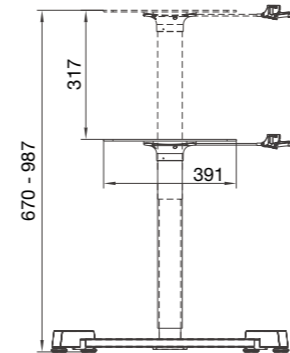

JSSY-S22S

HAND CRANK ADJUSTABLE DESK FRAME

SURFACE COLOR

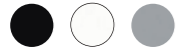

Black / White / Silver

Color can be customized

TECHNICAL PARAMETER

Height (mm)	690 ~ 1150	Width (mm)	1010 ~ 1450
Speed (mm/cycle)	16	Load Capacity (N)	800

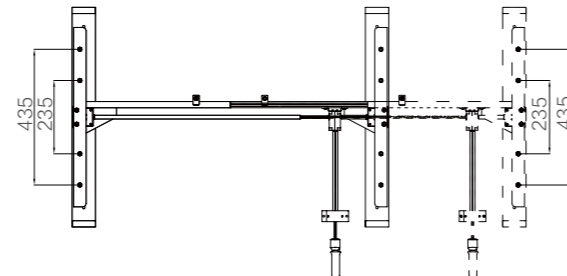
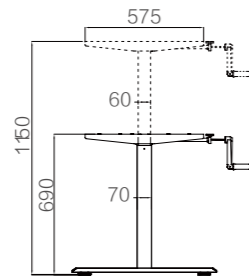
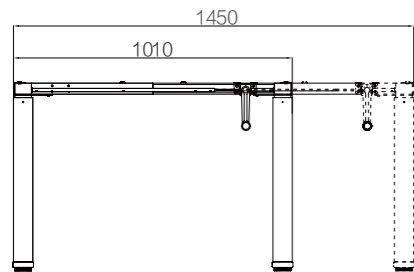

JC35SD

DESK CONVERTER

SURFACE COLOR



Black / White

TECHNICAL PARAMETER

Height (mm)	85 ~ 525	Load Capacity (N)	50
Speed (mm/s)	35	Noise (dB)	< 50



TECHNICAL PARAMETER

Height (mm)	85 ~ 525	Load Capacity (N)	50
Speed (mm/s)	35	Noise (dB)	< 50

TECHNICAL PARAMETER

Height (mm)	26 ~ 461	Load Capacity (N)	50
Speed (mm/s)	35	Noise (dB)	< 50

LIFTING COLUMN

LIFTING COLUMNS BRING POSSIBILITIES OF INNOVATION FOR FURNITURE

The lifting column is one of the most important component to compose intelligent adjustable furniture. It is widely used in various height adjustable workstations, meeting desks, talk tables and other adjustable products.

MULTIPLE CHOICES, CUSTOMIZED AS YOU WANT

Rectangle, square, circular, elliptical and other diversified appearance designs.
Two or Three segments columns can meet the demands of our customer's height choice.
No-hole and oil-free design, made for a better appearance and for an easier maintenance.
Compatible with JIECANG motor of comprehensive mechanical properties, high stability, high load, low noise, excellent performance.



CUSTOM COLOR

200+ COLORS ARE OPTIONAL

Multiple colors can match various application scenarios.
The actual color plate shall prevail.

CLASSIC COLORS



RAL 9016



RAL 7045



RAL 9005



RAL 9003



RAL 9010



RAL 9018



RAL 7043



RAL 9017

OTHER COLORS



RAL 9002



RAL 1000



RAL 6018



RAL 3012



RAL 7032



RAL 6027



RAL 1016



RAL 6001



RAL 3024



RAL 4006



RAL 5012



RAL 2003



RAL 6016



RAL 3001



RAL 8003



RAL 5013



RAL 8011



RAL 6028



RAL 3004



RAL 8016

3-STAGE LIFTING COLUMNS

TECHNICAL PARAMETER

Stroke (mm)

650

Height (mm)

560 ~ 1210

Load Capacity (N)

800

Speed (mm/s)

40

JS36DR1-3-S

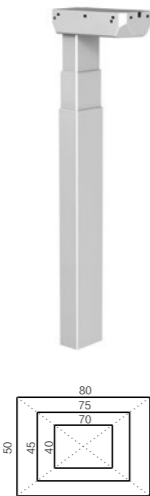

JS36DR1-3-R

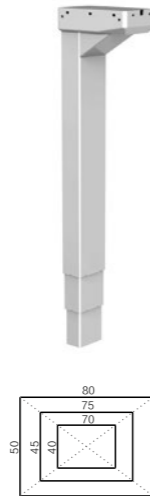

JS36DR2-3-S



JS36DR3-3-S



JS36DR4-3-S



JS36DR7-3-S



JS36DS1-3-S



JS36DS1-3-R



JS36DS3-3-S



JS36DS4-3-S



JS36DS4-3-R



JS36DS5-3-S



JS36DS9-3-S



JS36DC1-3-S



JS36DC1-3-R



JS36DE1-3-S



JS36DE2-3-S



2-STAGE LIFTING COLUMNS

TECHNICAL PARAMETER

Stroke (mm)

500

Height (mm)

650 ~ 1150

Load Capacity (N)

800

Speed (mm/s)

32

JS36DR1-2-S

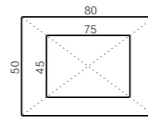

JS36DR1-2-R

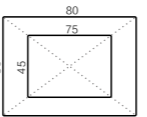

JS36DS5-2-S

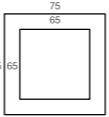

JS36DS9-2-S

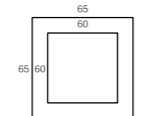

JS36DC1-2-S

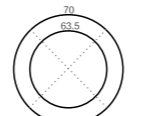

JS36DE1-2-S

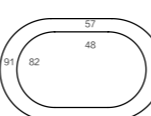

INLINE LIFTING COLUMNS

TECHNICAL PARAMETER

Stroke (mm)

650

Height (mm)

560 ~ 1210

Load Capacity (N)

800

Speed (mm/s)

40

JS36ZR2-3-S

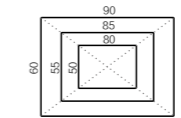

JS36ZR4-3-S

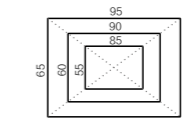

JS36ZS8-3-S

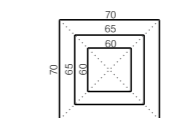

JS36ZS10-3-S

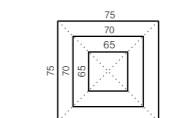

JS36ZC1-3-S

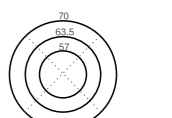

TECHNICAL PARAMETER

Stroke (mm)

500

Height (mm)

650 ~ 1150

Load Capacity (N)

800

Speed (mm/s)

32

JS36ZR2-2-S

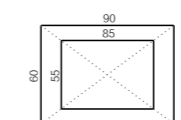

JS36ZS1-2-S

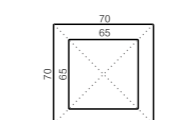

JS36ZC1-2-S

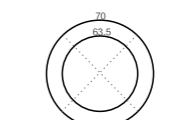

JS36ZE1-2-S

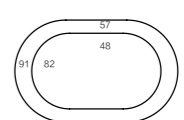

LIFTING COLUMNS FOR SPECIAL USE

JC35EN-2K



TECHNICAL PARAMETER

Stroke (mm)	Load Capacity (N)	Speed (mm/s)
400	1500	30
Height (mm)	Section size (mm)	
560 ~ 1050	145x112 / 164x131	

JC35EN3A



TECHNICAL PARAMETER

Stroke (mm)	Load Capacity (N)	Speed (mm/s)
665	1000	35
Height (mm)	Section size (mm)	
525 ~ 1190	125.3x92.3 / 130.3x163.3 150x183	

JS36H2



TECHNICAL PARAMETER

Stroke (mm)	Load Capacity (N)	Speed (mm/s)
500	500	30

CONTROL BOX



JCB36N1



JCB36N2



JCB36N3



JCB36N4



JCB35NS1



JCB35NS2

Model	JCB36N1	JCB36N2	JCB36N3	JCB36N4	JCB35NS1	JCB35NS2
Columnconnect No.	1~2	1~2	1~3	1~4	1	1~2
InputVoltage (V)	110/230	110/230	110/230	100~240	100~240	110/230
Transformerpower (W)	200	400	500	600	130	400

CONTROL BOX



JCB35NH2



JCB36M



JCB36MH3



JCB36M1



JCB36M3



JCB36M4

Model	JCB35NH2	JCB36M	JCB36MH3	JCB36M1	JCB36M3	JCB36M4
Columnconnect No.	1~2	1~2	1~3	1	2	4
InputVoltage (V)	100~240	18~33	24~32	29	29	33
Transformerpower (W)	400	144	240	144	144	576

HANDSET



JCHT35K

- 4 Memory Buttons
- Black
- LED



JCHT35K9

- 4 Memory Buttons
- Black
- LED
- USB Charger



JCHT35K11

- 3 Memory Buttons
- Water-proof on the Front Side
- Silicone Button
- 90° mounting angle
- Black / White / Grey / Green



JCHT35K24A

- Up&Down Button
- Seesaw Button



JCHT35K24B

- Up&Down Button
- Seesaw Button
- LED



JCHT35K24C

- 3 Memory Buttons
- Seesaw Button
- LED
- USB Charger



JCHT35K24S

- 3 Memory Buttons
- Seesaw Button
- LED
- Bluetooth
- USB Charger



JCHT35K20

- Operate by tilting for up and down
- Acrylic Material
- With different back light color options
- Shapes can be customized



JCHT35K23

- 2 Memory Buttons
- Acrylic Material
- With different back light color options
- Sedentary Reminder
- OLED

HANDSET



JCHT35K26A

- Up&Down Button
- Top Mounted
- Multiple colors
- Silicone Button



JCHT35K26B

- Up&Down Button
- Top Mounted
- Multiple colors
- LED
- Silicone Button



JCHT35K26C

- 3 Memory Buttons
- Top Mounted
- Multiple colors
- LED
- Silicone Button



JCHT35K26A

- Up&Down Button
- Side Mounted
- Multiple colors
- Silicone Button



JCHT35K26B

- Up&Down Button
- Side Mounted
- Multiple colors
- LED
- Silicone Button



JCHT35K22

- 3 Memory Buttons
- Water-proof on the Front Side
- Silicone Button
- 34° mounting angle
- Black / White / Grey / Green



JCHT35K49A

- Up&Down Button
- USB Charger



JCHT35K49B

- Up&Down Button
- LED
- USB Charger



JCHT35K49C

- 3 Memory Buttons
- LED
- Child lock function
- USB Charger

HANDSET



JCHT35K50A

- Operate by tilting for up and down
- Indicator lights



JCHT35K50B

- Operate by tilting for up and down
- LED



JCHT35K50C

- 2 Memory locations
- Operate by tilting for up and down
- OLED
- Sedentary Reminder
- Child lock function



JCHT35K52C

- 2 Memory Buttons
- LED
- DIY keyboard keys
- Light adjustment



JCHT35M13

- 3 Memory Buttons
- Touch Screen
- LED
- 34° or 90° mounting angle



JCHT35L

- Up&Down Button
- Black



JCHT35M6

- 3 Memory Buttons
- Touch Screen
- OLED
- Operate by rotating for up and down
- Sedentary Reminder



JCHT35M33A

- Made of leather
- Up&Down Buttons



JCHT35M33C

- Made of leather
- Up&Down Buttons
- 2 Memory locations

HANDSET



JCHT35K32C

- 3 Memory Buttons
- Water-proof on the Front Side
- Silicone Button
- LED



JCHT35K33C

- 3 Memory Buttons
- Water-proof on the Front Side
- Silicone Button
- LED



JCHT35M18C

- 3 Memory Buttons
- Water-proof on the Front Side
- Touch Screen
- Light Wake
- LED



JCHT35M19C

- 3 Memory Buttons
- Water-proof on the Front Side
- Touch Screen
- Light Wake
- LED

ACCESSORIES

CUSTOMIZED LIFTING SCREEN



JC35SP01

- Length: 900-1500mm
- Width: 600mm
- Thickness: 15-30mm
- LoadCapacity: 100N
- Stroke: 485mm

2.4G WIRELESS ADAPTER



JCP35N-2.4G

- Input power: 5V
- Remote control frequency: 2.4GHz
- Transmission distance: 8M

LITHIUM BATTERY



JCP35PA-B-3

- Mobile office
- Low power consumption
- USB charger
- Safe & fast charging

BLUETOOTH ADAPTER



JCP35N-BLT

- Plug in the Bluetooth receiver box on the control box, then turn on the Bluetooth and control the adjustable table through the APP on mobile phone

CABLE CHAIN

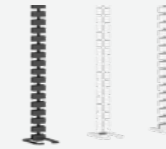

J-TSXG01

- Standard size(mm): 90*120*1400
- Accept any customized length
- Color: White/Black/Chroma

USB CHARGER



JCP35U

- Color: Black / White
- Charging for Mobile device, desktop
- Tighten with screws or fix with clamps
- Fit with JCB35NS2 control box

SIX AXIS SENSOR



JCB35N-6AXIS

- Intelligent anti-collision accessories
- High sensitivity, stable operation

WIRELESS CHARGER



JCP35WA-A

- Power the phone wirelessly
- Under the desktop
- Compatible with control boxes: JCB35NS1, JCB35NS2

WIRE MANAGEMENT

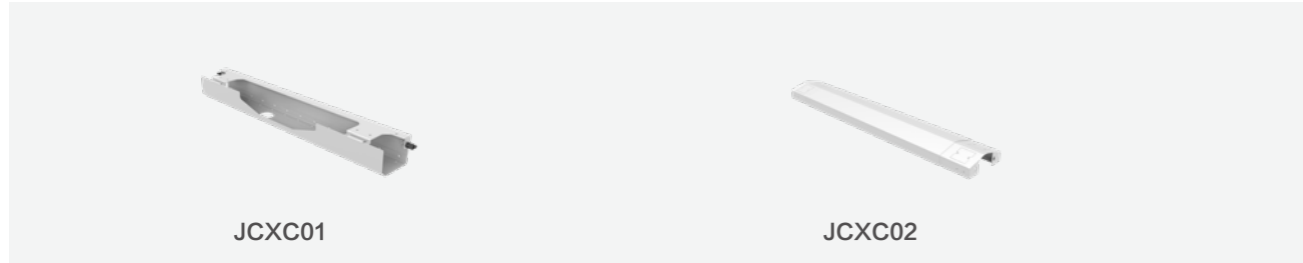

JCXC01

- Length: 762mm
- Width: 99.8mm
- Height: 74.5mm

JCXC02

- Length: 950mm
- Width: 205mm
- Height: 73.5mm

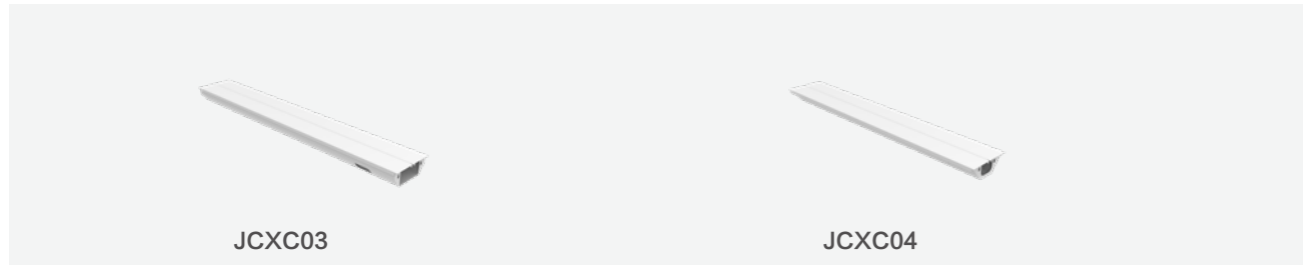

JCXC03

- Length: 1351mm
- Width: 200mm
- Height: 72mm

JCXC04

- Length: 1264mm
- Width: 192.4mm
- Height: 71.8mm

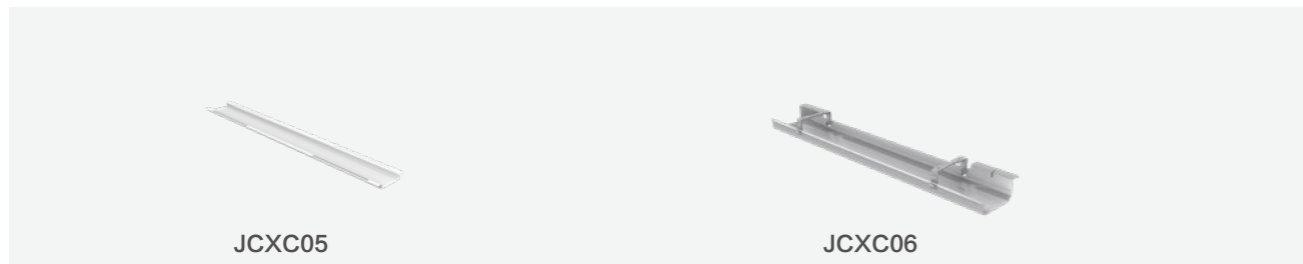

JCXC05

- Length: 1000mm
- Width: 136mm
- Height: 18mm

JCXC06

- Length: 900mm
- Width: 173mm
- Height: 60mm

FOOT SERIES



JCF001

- Length: 680mm
- Width: 80mm
- Hole Pattern: 58*34mm

JCF084

- Length: 580mm
- Width: 80mm
- Hole Pattern: 52*26mm

JCF254

- Length: 700mm
- Width: 85mm
- Hole Pattern: 58*34mm



JCF197

- Length: 700mm
- Width: 60mm
- Hole Pattern: 14*14mm

JCF095

- Length: 700mm
- Width: 80mm
- Hole Pattern: 58*34mm

JCF073

- Length: 975mm/625mm
- Width: 80mm
- Hole Pattern: 58*34mm



JCF072

- Length: 700mm
- Width: 78mm
- Hole Pattern: 58*34mm

JCF093

- Length: 603mm
- Width: 73mm
- Hole Pattern: 52*26mm

JCF323

- Length: 680mm
- Width: 80mm
- Hole Pattern: 58*34mm/52*26mm

FOOT SERIES



JCF125

- Length: 700mm
- Width: 80mm
- Hole Pattern: 58*34mm

JCF157

- Length: 700mm
- Width: 65mm
- Hole Pattern: 50*40mm

JCF130

- Length: 700mm
- Width: 70mm
- Hole Pattern: 32.5*32.5mm

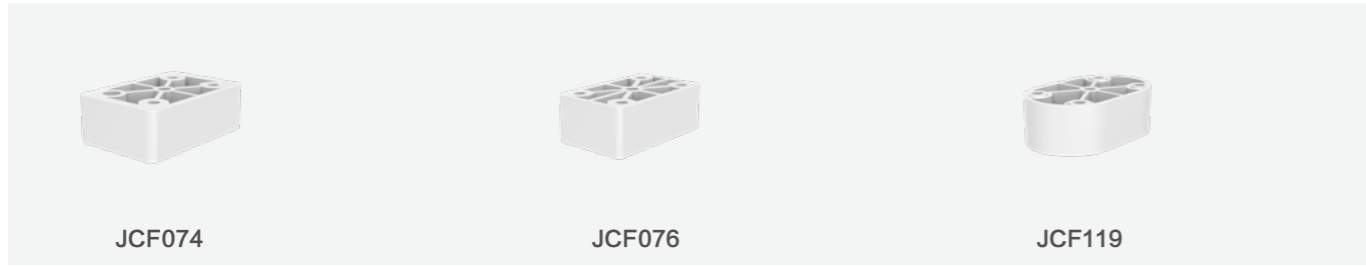

JCF074

- Length: 90mm
- Width: 60mm
- Hole Pattern: 58*34mm

JCF076

- Length: 80mm
- Width: 50mm
- Hole Pattern: 58*34mm

JCF119

- Length: 91mm
- Width: 57mm
- Hole Pattern: 58*34mm

CONTROL SYSTEM

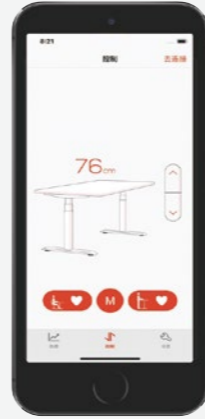

START A HEALTHY OFFICES STATE, MAKE YOUR LIFE FULL OF POSSIBILITIES

Up & Down control / Sit & Stand reminder / Office data statistics / used in mobile and computer



AIDESK Control System

- Control UP & DOWN by mobile phone
- Applicable for android and IOS system
- Sedentary reminder function



AIWORKING Desk Control Software

- Control by computer software
- Display the height
- Show the standing-time and calorie-buring results
- To memory the height of standing and sitting
- Statistical datas and health management

Headquarters

Xinchang

📍 ADD : Provincial High Tech Park, Xinchang County, Zhejiang Province, China

✉ EMAIL : jc35@jiechang.com

☎ TEL : +86-575-86297980

📠 FAX : +86-575-86297960

Global Divisions

Ningbo

📍 ADD : Linxu Road&Chaosheng North Crossroad, Cidong Economic Development Area, Cixi, Ningbo, Zhejiang, China

Guangzhou

📍 ADD : No.114, Building 4, Qixi creative park, No.24 Xinyi road, Fangcun avenue east, Liwan district, Guangzhou, China

✉ EMAIL : sales24@jiechang.com

☎ TEL : 020-89114036

📠 FAX : 020-89114037

America

📍 ADD : 500 West Street, Cedar Springs, MI 49319

✉ EMAIL : john@jiechang.com

☎ TEL : +616-952-0630

Germany

📍 ADD : Emanuel-Leutze-Str.11, 40547 Düsseldorf, Germany

✉ EMAIL : jing@jiechang.com

☎ TEL : +49(0)21156677116

Japan

📍 ADD : 1F, 13-34-3, Ikebukuro, Toshimaku, Tokyo, 171-0014, Japan

✉ EMAIL : jsjp03@jiechang.co.jp

☎ TEL : +03-6206-6856

📠 FAX : +03-6206-6857

India

📍 ADD : 1204, Best Sky Tower, Netaji Subhash Place Pitampura, Delhi-110034

✉ EMAIL : fahim@jiechang.com

☎ TEL : +91-7483686104

Malaysia

📍 ADD : 79200 Iskandar Puteri, Johor, Malaysia

☎ TEL : +60 12-685 7772

Brazil

📍 ADD : JSTAR do Brasil Importação e Comércio Ltda.São Paulo, SP

✉ EMAIL : felipe.grams@jstarmovimento.com

☎ TEL : +551195550-9512

