

WORKHOLDING APPLICATION BOOKLET

Applications and advantages of using
miniBOOSTER hydraulic pressure intensifiers

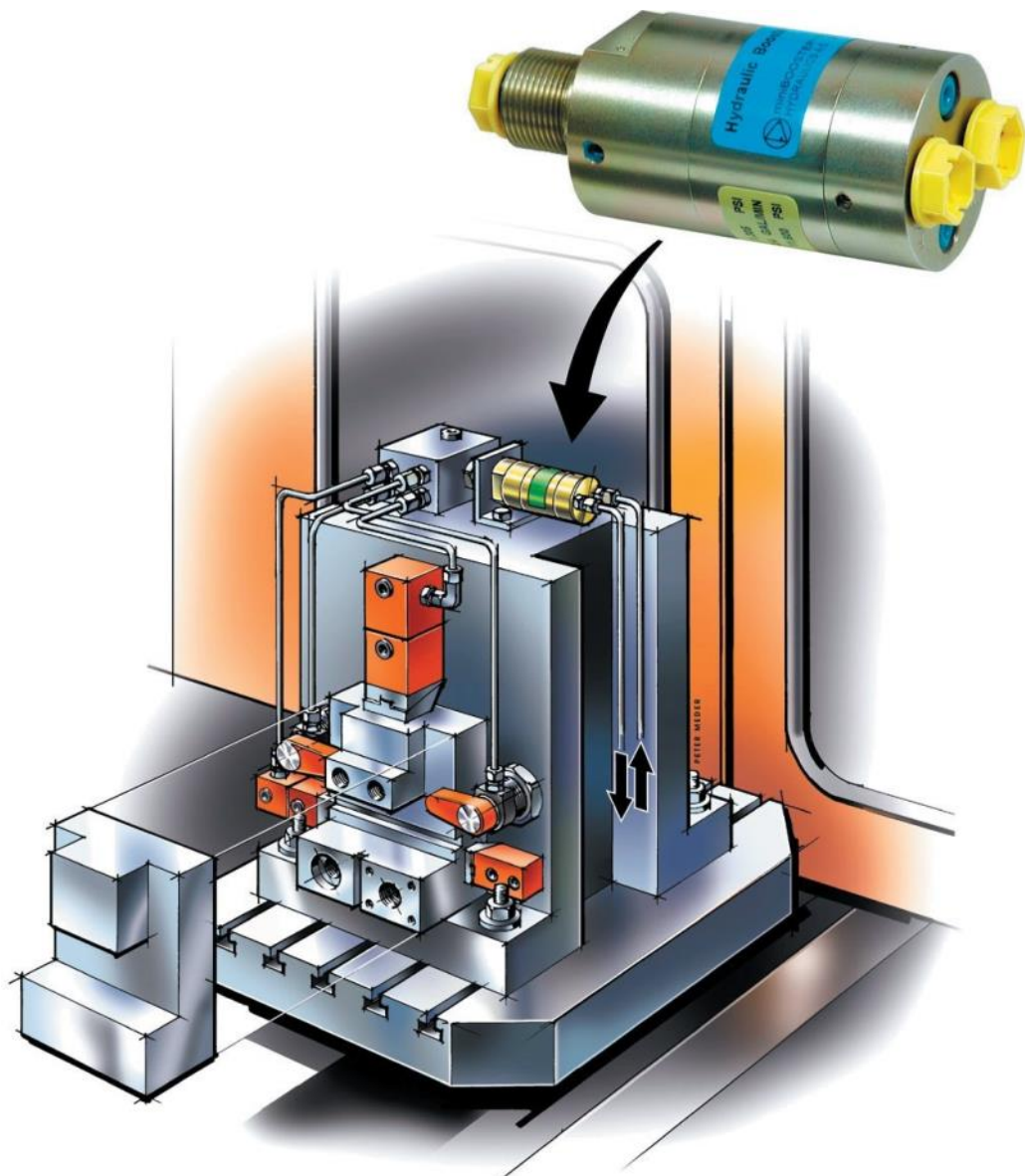

MINIMUM SIZE – MAXIMUM POWER

Table of Contents

Table of Contents	3
miniBOOSTER in Hydraulic Workholding	4
How does the miniBOOSTER work?	5
A typical pallet circuit.....	6
Advantages of high pressure hydraulics	7
How to choose the optimal miniBOOSTER.....	8
Getting rid of spaghetti tubing	9
Unclamping cross rails	10
Fixing of indexing heads	11
Machine spindle application	12
Rotary Applications	13
Optimising clamping speed	14
Direct Proportionally Controlled Boosters.....	15
Two clamping forces in one proces step	16
Filtration.....	17
Hydraulic clamping on servo driven machines	18

miniBOOSTER in Hydraulic Workholding

Hydraulic miniBOOSTERS are used widely in machine tools especially in connection with workholding tools like clamps and support cylinders.

Often machine tools have a hydraulic system generating 30 - 100 bar, and most hydraulic workholding systems require operational pressures of 150 - 500 bar.

By simply inserting a miniBOOSTER between the hydraulic system of the Machine Tool and the workholding system, any pressure can be obtained.

The control of the clamping and the unclamping of parts can be done from the low-pressure side via the miniBOOSTER, giving a simple and reliable method of operation.

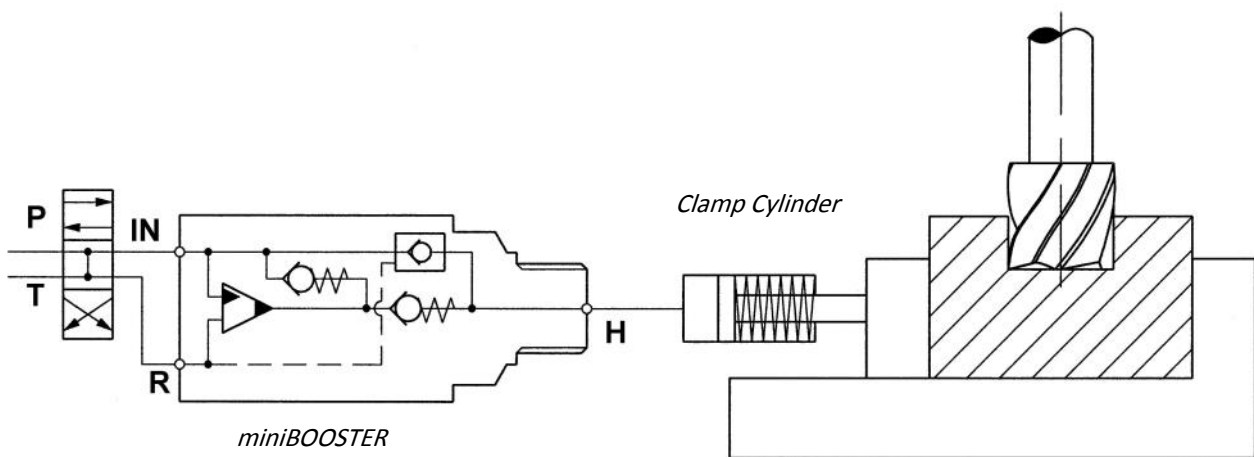

Function diagram: 0-103

Installing a miniBOOSTER will give significant benefits:

Less investment. Whatever you are comparing a miniBOOSTER solution with a high-pressure pump or a low-pressure clamping circuit, you will see big savings. Please remember that all hoses/tubes and valves can be rated for low pressure.

Less space. The miniBOOSTER is very compact and takes up significantly less floor space.

Less noise. The miniBOOSTER is very quiet generating only 64dBa, compared to high-pressure pumps generating 70 dBa to 90 dBa.

Lower operating cost. The miniBOOSTER does not need any maintenance, as it has no dynamic sealings.

How does the miniBOOSTER work?

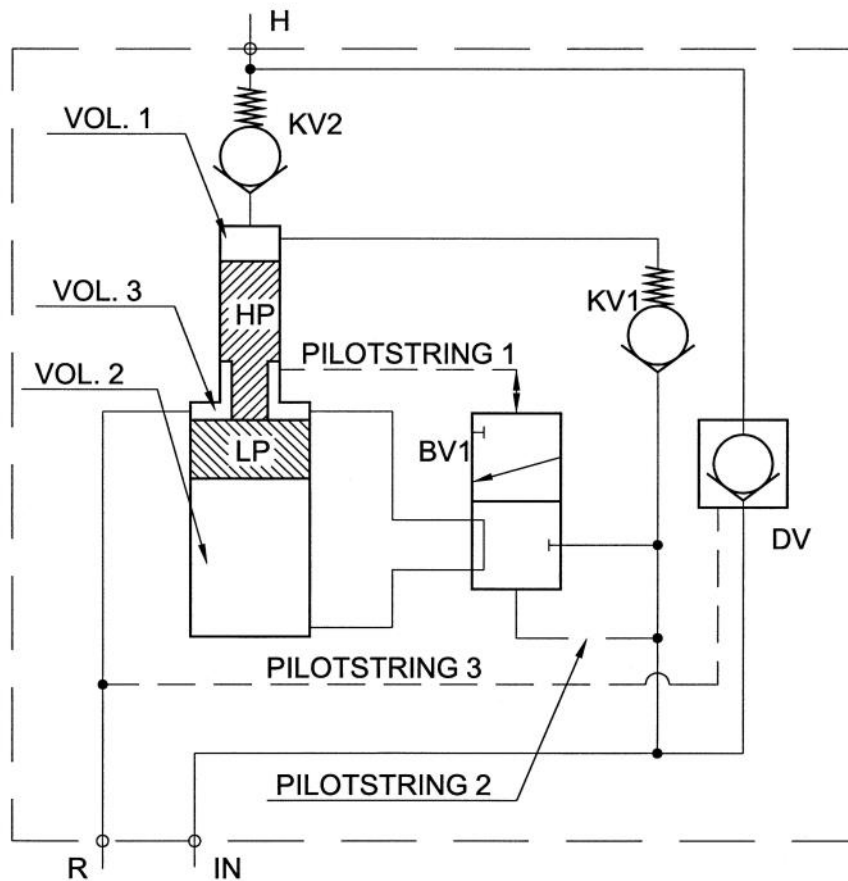

Function diagram: 0-101

- ▶ Oil is led to port IN and passes through the check valves KV1, KV2 and DV incorporated here to the high-pressure side H.
- ▶ In this situation all the oil flow from the pump goes right through the miniBOOSTER, and a cylinder on the high-pressure side H will move fast forward.
- ▶ When the cylinder meets resistance, check valves KV2 and DV close.
- ▶ As pump pressure is applied to Vol. 1 the pistons move down.
- ▶ The bistable valve BV1 connects Vol. 2 to tank over Vol. 3.
- ▶ When the pistons have been moved fully down, pilot string 1 is pressurized and the bistable valve BV1 changes position.
- ▶ The oil flow from the pump is led to Vol. 2 making the pistons move. Upward delivering fluid at the desired end pressure.
- ▶ Once the high-pressure piston HP has been moved fully up. Pilot string 1 is connected to tank, the bistable valve BV1 shifts to its original position.
- ▶ The cycle is repeated until the required end pressure has been established.
- ▶ The pressure relief of the high-pressure side can be done through the pilot operated check valve DV.
- ▶ By connecting port R to the pump and port IN to tank, pilot string 3 will be pressurized, allowing the oil from the high-pressure side H to flow back to tank.

A typical pallet circuit

The pallet is connected to the machining centre by quick couplings; they transfer the system pressure (30 to 100 bar) to the pallet at the loading station and maintain it in the workstations.

The filter protects the hydraulics from chips that might enter the system via the quick connectors.

To avoid any pressure to build up in the R line, it is important that the quick connectors automatically open if for any reason the pressure increases above 5 bar.

Too high pressure in the return line may open the dump valve and release the clamping force.

As an additional safety it is recommended to install a non-leak pilot operated valve to secure that the clamping force is maintained, even if contamination (chips) should be trapped in the check valve inside the booster.

The accumulator secures that the pressure is kept stable, even under temperature variations, which may occur when the pallet is stored in a cold place.

It is not recommended to install the accumulator at the low-pressure side.

The booster has no dynamic sealings and even a small leakage between IN and R will over time build pressure in the R line. This will lead to the opening of the dump valve and finally release the clamping force.

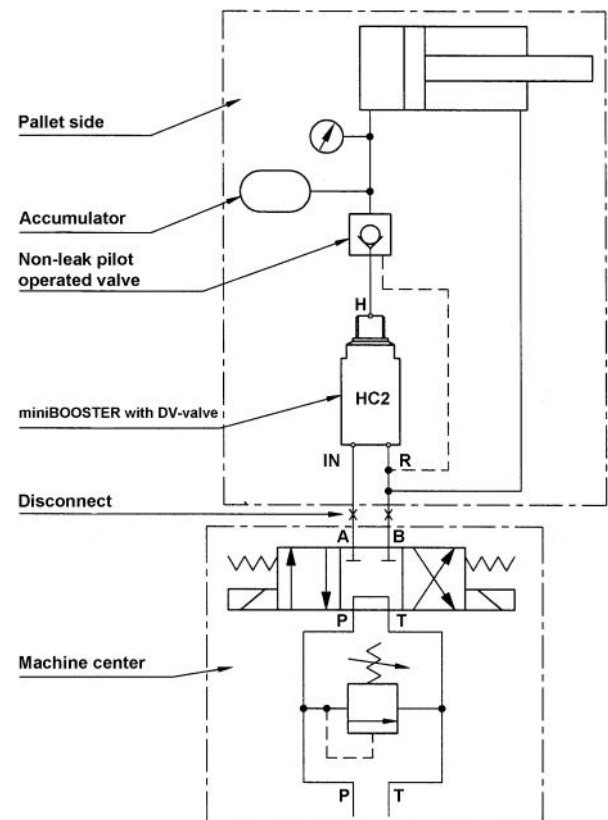

Function diagram: 0-119

Advantages of high pressure hydraulics

Raising the hydraulic pressure from 80 to 400 bar, allows you to use smaller high-pressure components (clamps and support cylinders), typically 1 to 2 sizes down.

Lower fixture cost.

Reduced prices of clamps and support. Cylinders (typically 50%).

More parts per pallet.

The smaller high-pressure clamps gives you more space on the pallet, allowing you bigger items or more items on your pallet.

Reduced clamp time.

The smaller high-pressure clamps need less oil to be injected during the clamping, reducing the clamping time 3 to 5 times.

Example 1: A swing clamp designed for a clamping force of 1000 Newton = 1 ton

System pressure	80 bar	400 bar
List price	600 EUR	364 EUR
Body diameter	90 mm	60 mm
Oil volumen	75 cc	28 cc
miniBOOSTER		800 EUR

Example 2: The miniBOOSTER distributor offered both a high-pressure and a low-pressure solution - the customer ordered the high-pressure solution.

A system with 2 pallets each containing 9 swing clamps and a support cylinder, pressure reducing valve and a filter.

The following advantages were realised increasing the pressure from 100 bar to 400 bar, with the help of 2 off HC3-4.0

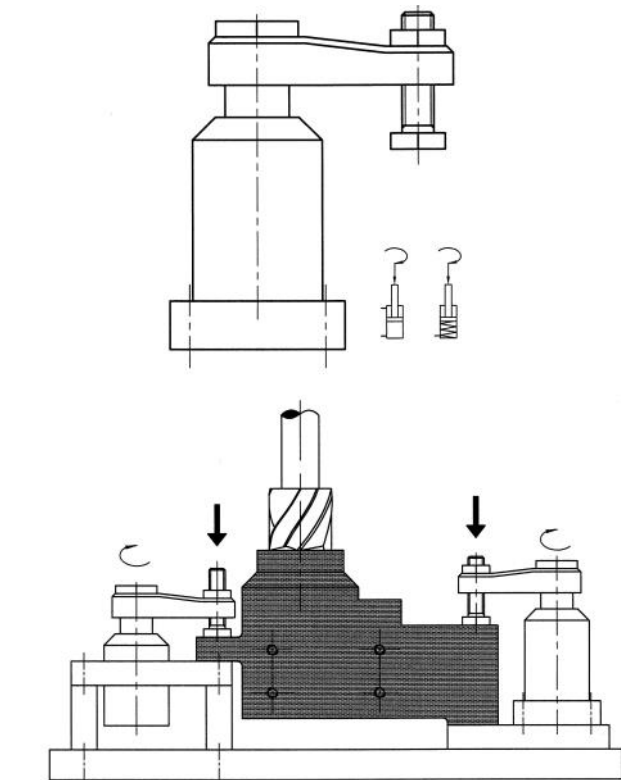

Function diagram: 0-344

Reduction of component price from 12,463 EURO to 9,979 EURO 20%

Reduction of oil filling volume 1300cc to 240 cc 5 times

With a pump flow of 2 liters per minute (33 cc/sec) clamping and unclamping were reduced in total with 60 seconds per cycle.

How to choose the optimal miniBOOSTER

miniBOOSTER offers a wide range of hydraulic pressure intensifiers.

In both the HC2 and HC3 series you can choose between 11 different intensification ratios from 1.2 to 20 providing the decided end pressure.

You can choose between B models with dump valve, A models without dump valve, or G models see page 14

In pallet systems, the B versions with built-in dump valve, gives you a convenient and compact solution releasing the clamp force.

You have the choice between tubing HC2 & HC2D, or flanged versions NG6 (DO3), where HC3 manifold system offers a very clean design with an easy replacement possibility.

If you need speed, to fill bigger cylinders in a short time, a sequence valve (HC2-CV5) or a dual acting booster (HC2D) offer fast solutions.

The advantages of the dual acting boosters are realised with good system flow > 5 liters per minute, where the sequence valve offers benefits from the low flow.

If the pump flow is below the minimum 2 litres per minute, please have in mind that miniBOOSTER offers special solutions with lower start flow.



HC2

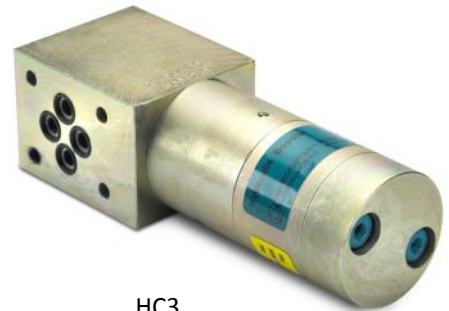

HC3



HC2-CV5

Getting rid of spaghetti tubing

The connections on the pallets are often made with tubings.

This solution has some disadvantages as the tubings are collecting chips and makes it difficult to clean and service the pallet.

With the use of long hole drilling it has become possible to run the hydraulics inside the pallet connecting to the components that now have to be flanged onto the pallet.

miniBOOSTER offers a number of flanged mounted boosters and filters in the HC3 series allowing a clean design and a fast replacement.

HC3



Rear of pallet



HC2

FIL-52T-10

Front of pallet

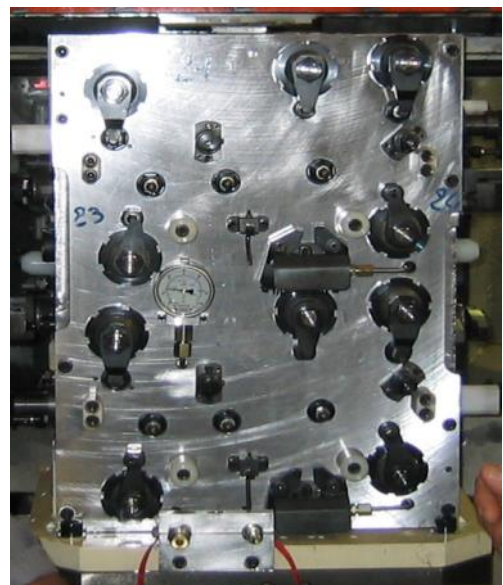

HC3 — Standard HC with NG6 (DO3) pattern

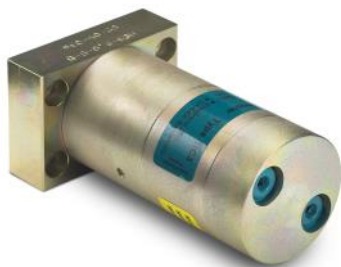

HC3-D - Flange version



HC3-F - Includes a 10 micron filter

Unclamping cross rails

Securing high precision, speed and force, the work head needs to be kept in a fixed position.

The clamping of the workhead is often done by using strong disc springs.

To get them as strong and small as possible they demand high pressure 200 to 400 bars for releasing.

The miniBOOSTER can be installed next to the disk spring simply using the system pressure.

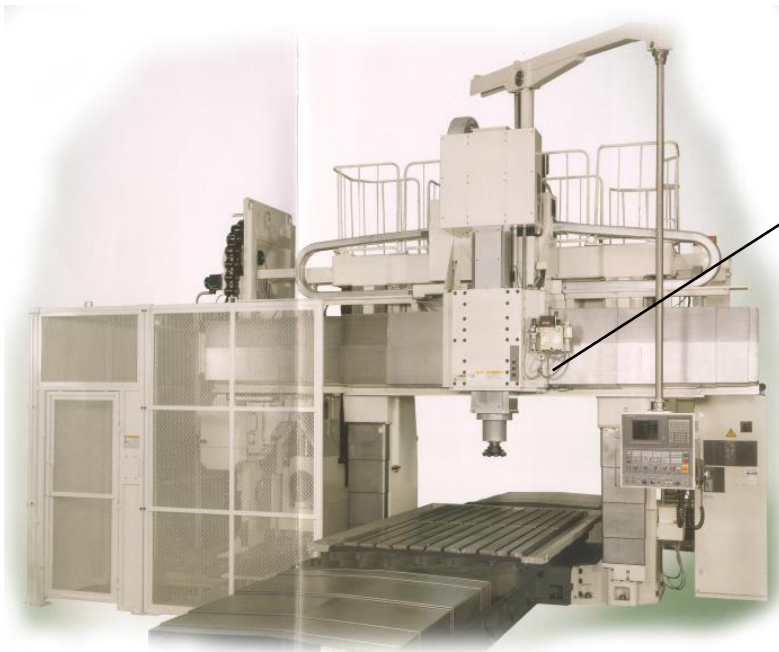

HC2

Unclamping the cross rail

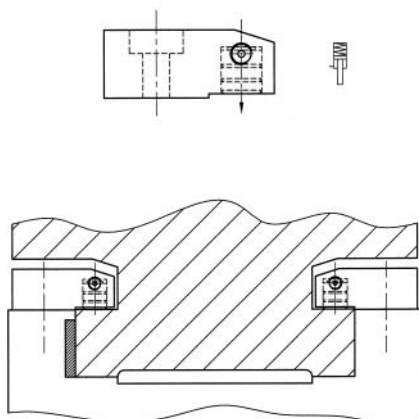

Function diagram: 0-345

Fixing of indexing heads

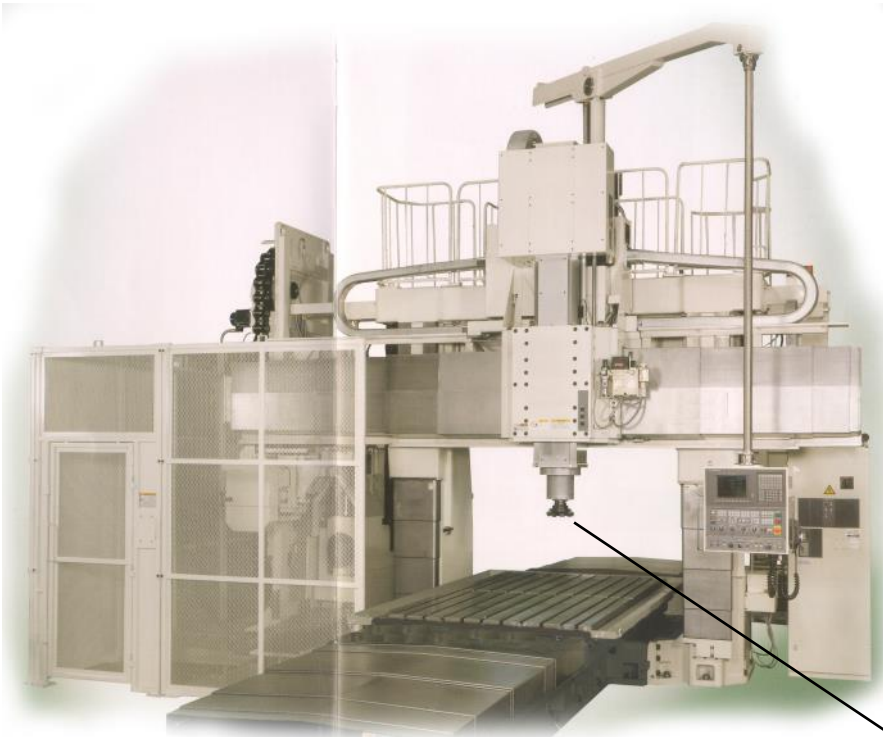

Unclamping tools inside spindle head



HC3

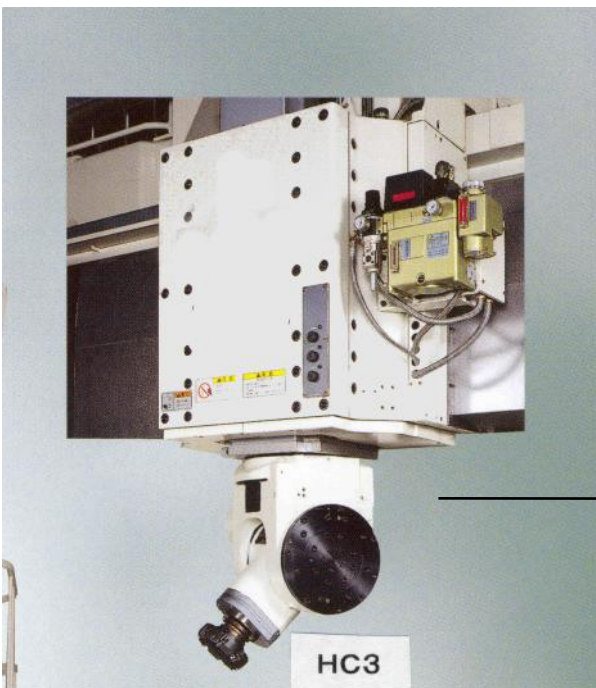

Clamping spindle (index) head



HC3

Machine spindle application

Releasing the tool from the conic tool holder can cause difficulties. The miniBOOSTER offers a good solution, creating the necessary releasing force.

Installing a sequence valve before the booster, ensures that the booster only oscillates when necessary, in the few cases where the tool sticks. In this case there is no reduction in releasing speed at all.



HC2 - CV5

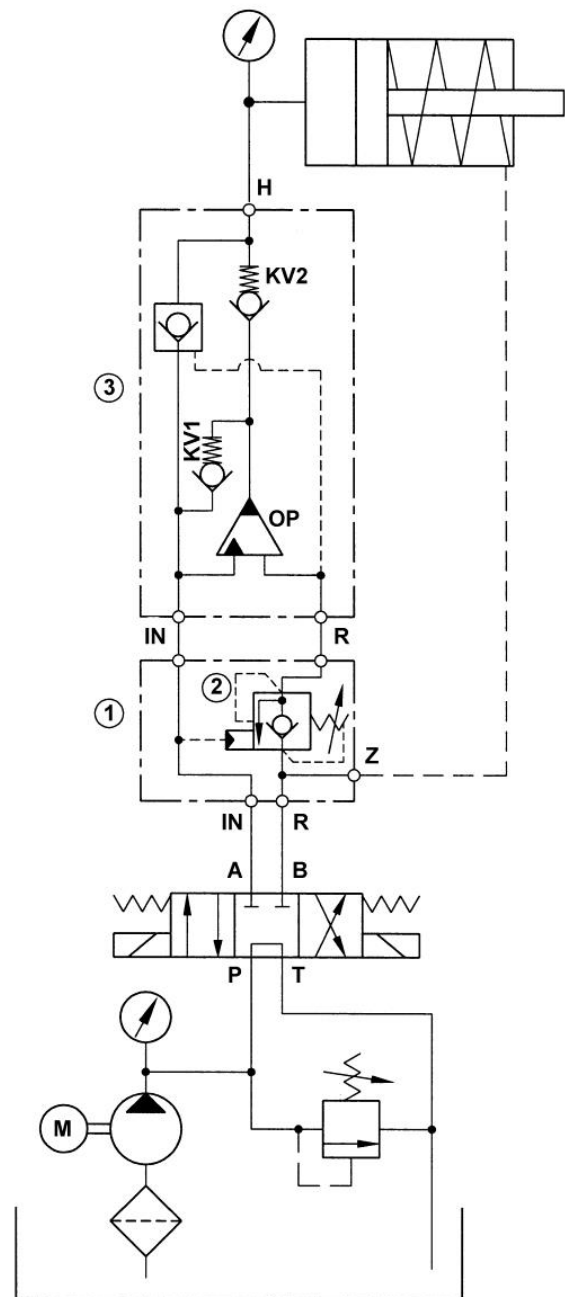
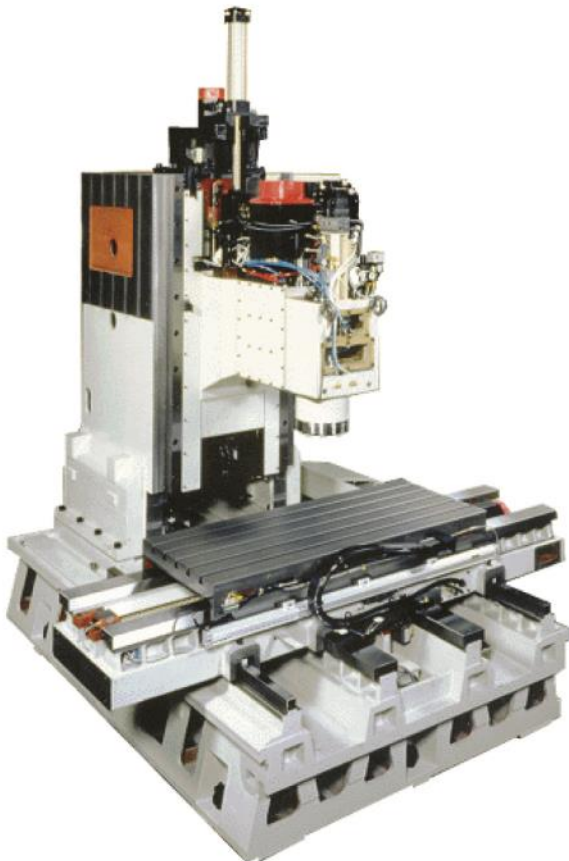

Function diagram: 0-207

Rotary Applications

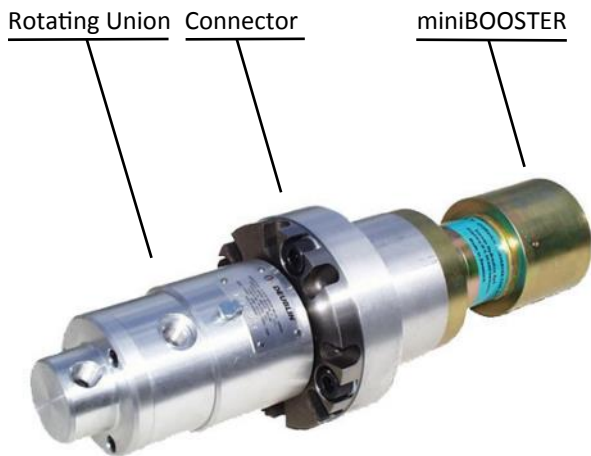

In rotary applications you can obtain high pressures (100, 200, 500, 1000 bar or even higher) using miniBOOSTER's.

The miniBOOSTER is connected to the machine's hydraulic pressure source through a hydraulic rotating union.

Besides the advantage of obtaining very high pressure, the low pressure transferred over the rotating union minimizes the oil spill and allows very high rotation speeds.

The miniBOOSTER will have the same turning speed as the turning part of the application, and boost the supplied pressure to the required end pressure.

Typical applications are rotating cutting knives and rotating clamps. On turning machines the possibility for having higher pressures is the solution to many technical difficulties.

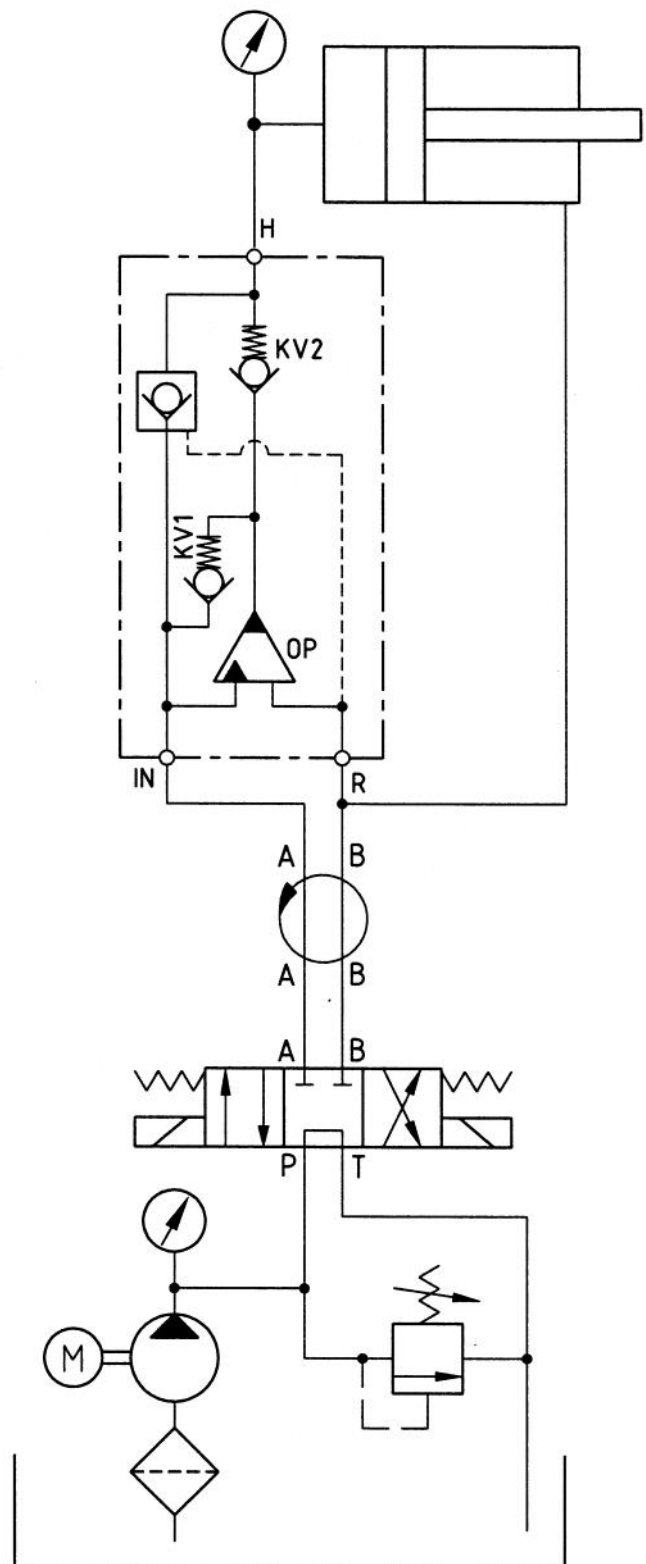

Function diagram: 0-239

Optimising clamping speed



Installing a sequence valve in front of your miniBOOSTER makes it possible to increase your clamping speed even further.

The sequence valve blocks the return port from the booster until a present pressure has been reached.

This will allow you to use the full pump flow to bring the cylinder / clamp in position, followed by a few strokes by the booster, increasing the pressure to the desired end value.

The pump pressure (as low as 50 bar) is in most cases able to overcome the back pressure from the spring (e.g. 30 bar).

By introducing a sequence valve (HC2-CV5) the full pump flow, up to 15 l/min through HC2, will go directly through the booster to the clamp or support cylinder bringing it into position.

When the present pressure has been reached. (e.g. 90% of pump pressure 45 bar) the sequence valve will open and the booster starts to oscillate raising the pressure.

The HC2-CV5 is a sequence valve block that can be mounted directly on the booster, giving you a very compact solution. The unit can be tested and pre-set from the factory, ready to mount.

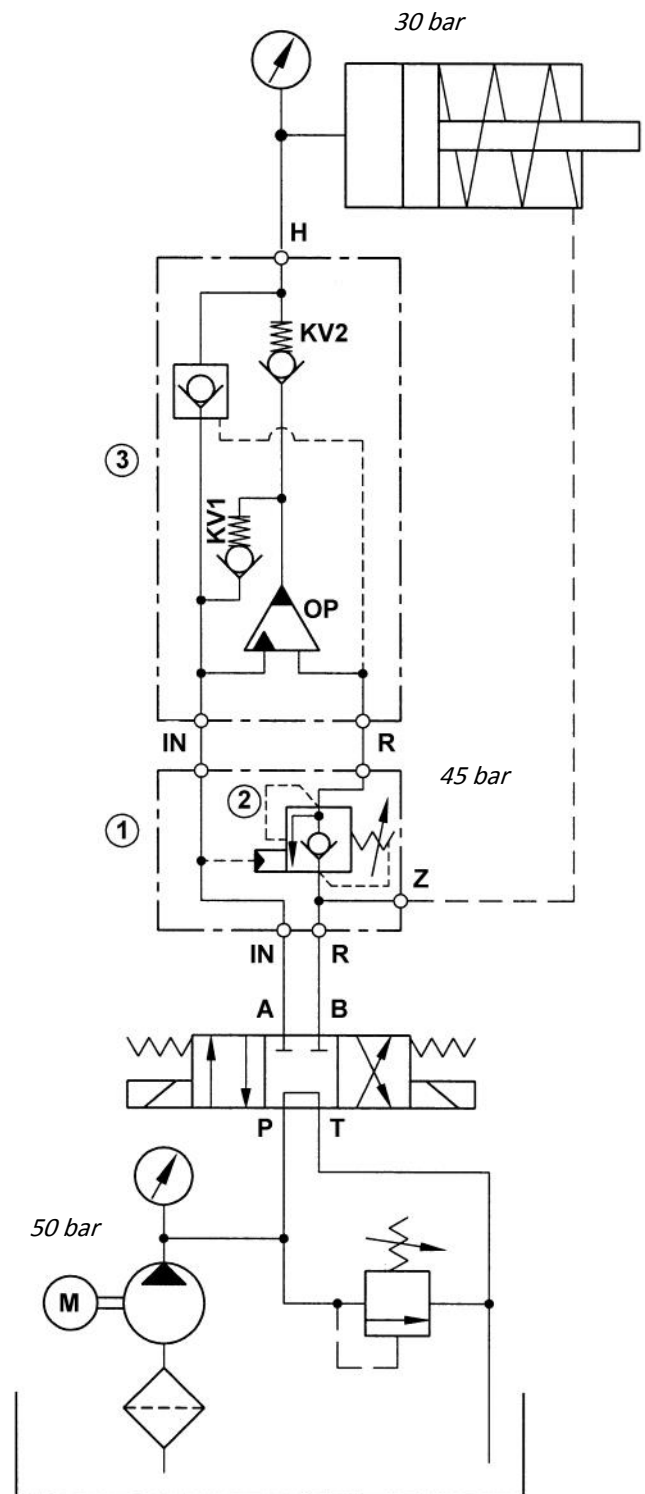

Function diagram: 0-207

Direct Proportionally Controlled Boosters

All boosters in the HC series can be delivered as Direct Proportionally Controlled, G models.

When the low-pressure side changes from 20 to 200 bar, the output will follow proportionally **up and down**. If the input pressure is reduced to 0 the output pressure also goes to 0.

The feature is controlled by the relieve valve RV which is matched with the intensification ratio of the mini-BOOSTER.

Application areas:

Work holding machines where different process steps demand different clamping pressures. Lifting application, pressure can be reduced slowly.

Off shore safety valves, all pressure must go to 0, when the electricity is switched off.

The direct proportional controlled boosters are in all sizes and performance equal to the A and B models.

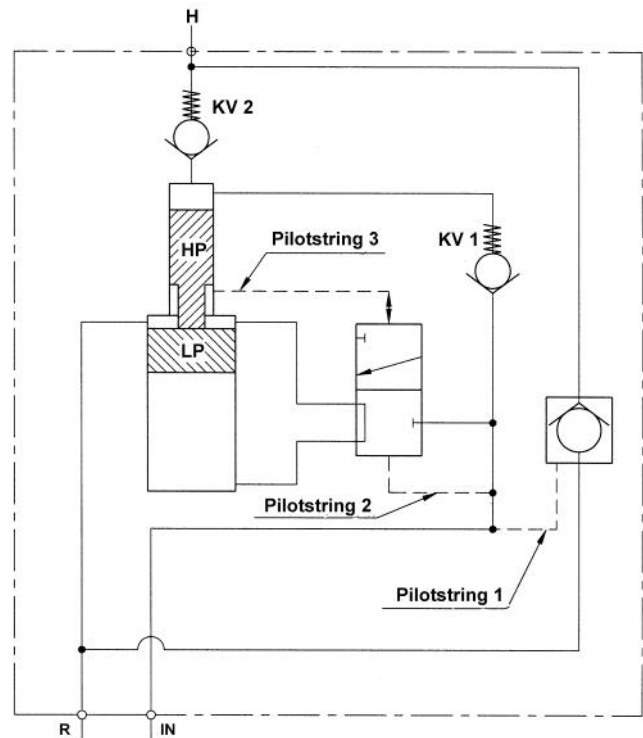

Function diagram: 0-128

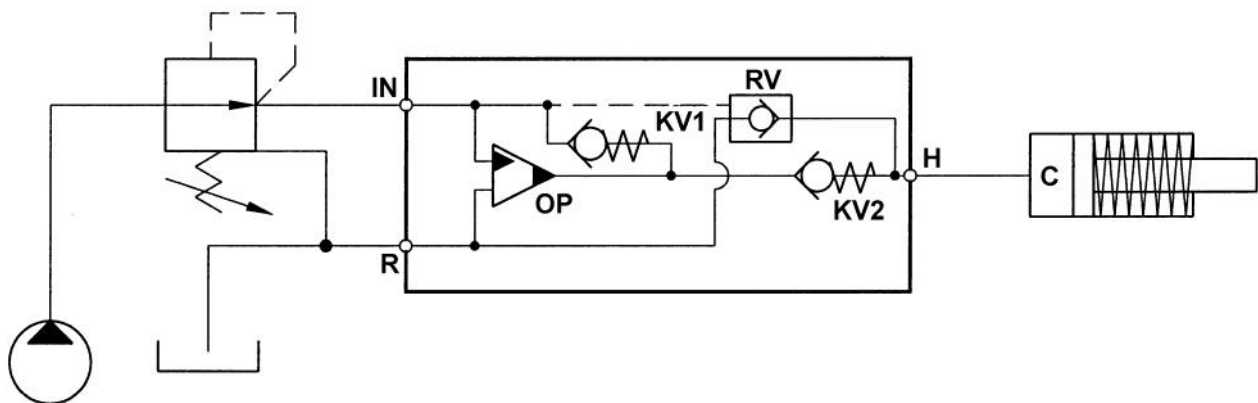

Function diagram: 0-134

Two clamping forces in one process step

For applications requiring 2 or more process steps with different clamping force, the G model is an ideal solution.

With a G model the high pressure follows the low pressure up and down, without having to dump and drop to 0, loosening the workpiece.

Typically the first process steps demand high clamping force for roughing, and lower force for finishing processes. The function diagram to the right shows the G model installed on a pallet application.

A stable high-pressure is secured by the non-leak - 2/2 valve and an accumulator.

This allows stopping or disconnecting the low pressure pump, when there is no changes in the process.

Preventing small pumps from running too much.

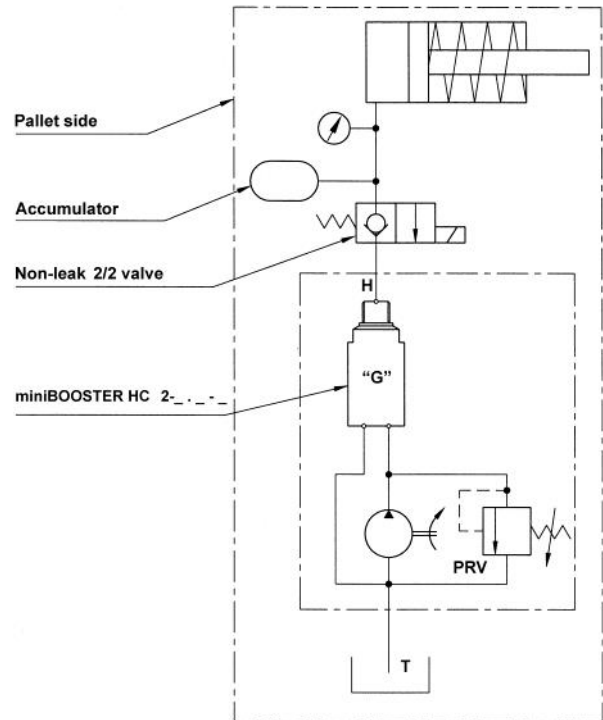

Function diagram: 0-123

Filtration

Contamination is the number one cause of failure in hydraulic systems. Failures cause downtime, component and fluid replacement, as well as higher maintenance charges.

Hydraulic filters deliver good protection against contamination, giving you predictable reliability for your hydraulic systems and components.

Regular exchange of the filter element is important, depending on the intensity of the usage. The filter has to be replaced at least once a year and in more intense usages every six months.

Fitted on the pressure side of a pump, it will protect the system and its control valves down to 10 microns.

FIL-52-10
Inline filter



FIL-52T-10
T filter

For fast replacement of filter element



HC2-CV6-1
Filter housing with blends and check valves
protecting reverse flow



FIL-NG6-10
NG6 (D03) filter with clogging indicator



Hydraulic clamping on servo driven machines

In a variety of applications where no hydraulic system is available, the compact self-priming booster pump HC2P offers a good solution providing pressure up to 800 bar.

The booster pump is an integration of a gear pump and a HC2 miniBOOSTER.

Like other miniBOOSTER models, the HC2P automatically compensates for consumption of oil to maintain the high pressure. Adjustment of the outlet pressure is carried out on the low-pressure side (gear pump).

Relative to its flow capability, the HC2P is a compact unit weighing only 2.1 kg.

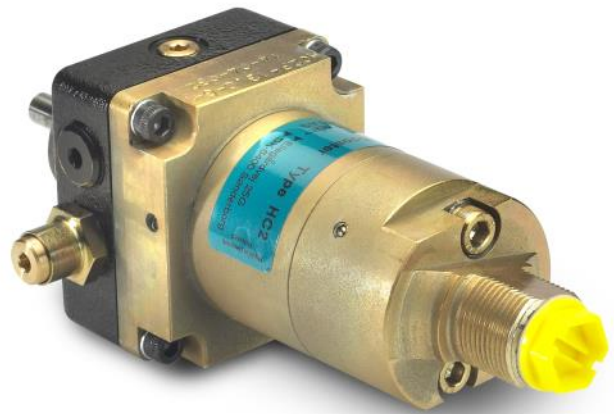

With the HC2P you have a closed circuit on the pallet, completely without the risk of oil spill into the cooling emulsion.

The HC2P offers an economical solution to implement hydraulic clamping on servo motor driven machining centres.

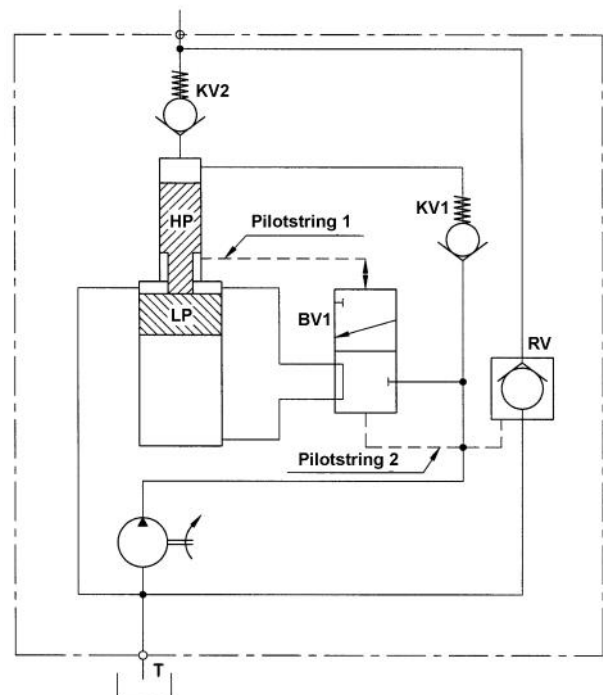

Function diagram: 0-131

For more information on miniBOOSTER Products, please visit our website at www.minibooster.com



The screenshot shows the miniBOOSTER website homepage. At the top left is the miniBOOSTER logo. To its right are social media icons for Google+, LinkedIn, YouTube, Facebook, and Twitter. Below these is a search bar with the word "SEARCH" and a magnifying glass icon. A navigation menu contains links for HOME, PRODUCTS, APPLICATIONS, PROMOTION, COMPANY INFO, and CONTACT US. The main content area features a large image of a blue industrial machine. To the right of the machine is a language selection dropdown menu with options: ENGLISH, DEUTSCH, RUSSIAN, CHINESE, SPANISH, JAPANESE, and FRENCH. Below the language menu is a product image labeled "HC7". Three promotional boxes are arranged horizontally: "LATEST NEWS Agriculture video" with a link, "BOOST YOUR HYDRAULIC PRESSURE!" with a diagram showing pressure increase from 20-200 BAR to UP TO 5000 BAR, and "SIGN UP FOR OUR NEWSLETTER" with input fields for Name and Email address, and a Sign up button. The footer contains contact information for miniBOOSTER Hydraulics A/S, office hours, and a digital clock showing 12:29. Navigation links for WEBMASTER, LEGAL NOTICE, and SITEMAP are also present.

The only full range of hydraulic intensifying solutions

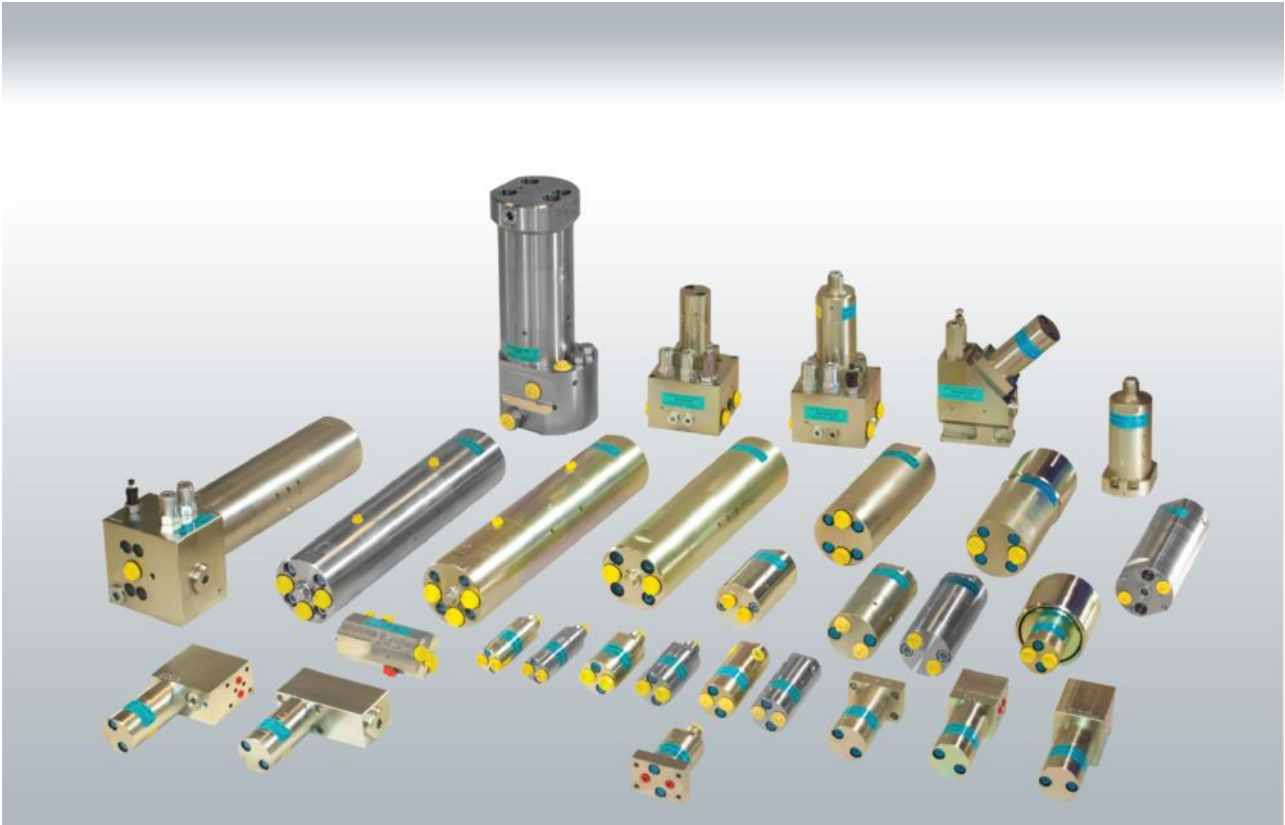

Authorised distributor: